

# User Guide

Lenovo  
YOGA

Lenovo

Yoga 7i 2-in-1 (14", 10), Yoga 7 2-in-1 (14", 10), Yoga 7i 2-in-1 (16", 10) and Yoga 7 2-in-1 (16", 10)

## Read this first

Before using this documentation and the product it supports, ensure that you read and understand the following:

- [Generic Safety and Compliance Notices](#)
- *Safety and Warranty Guide*
- *Setup Guide*

## HEVC Standard

This product may support digital video coding under certain versions of HEVC (High Efficiency Video Coding) standard and, if so, may be covered by patents at [patentlist.accessadvance.com](http://patentlist.accessadvance.com).



**Third Edition (February 2026)**

**© Copyright Lenovo 2025, 2026.**

LIMITED AND RESTRICTED RIGHTS NOTICE: If data or software is delivered pursuant to a General Services Administration "GSA" contract, use, reproduction, or disclosure is subject to restrictions set forth in Contract No. GS-35F-05925.

---

# Contents

## About this guide . . . . .iii

## Chapter 1. Meet your computer . . . . .1

Front view . . . . .	1
Microphones . . . . .	2
Infrared LED . . . . .	2
Infrared camera . . . . .	2
Camera shutter . . . . .	2
Camera . . . . .	3
Camera light . . . . .	3
Ambient light sensor . . . . .	3
Screen . . . . .	3
Top view . . . . .	4
Antennas . . . . .	5
Speakers . . . . .	5
Fingerprint sensor . . . . .	5
Touchpad . . . . .	5
Keyboard . . . . .	5
Microphones . . . . .	5
Left view . . . . .	6
HDMI connector . . . . .	6
Multi-purpose USB Type-C connector . . . . .	6
Charging light . . . . .	6
Combo audio jack . . . . .	7
Right view . . . . .	8
Power light . . . . .	8
Power button . . . . .	8
microSD card slot . . . . .	9
Multi-purpose USB Type-C connector . . . . .	9
USB Standard-A connector . . . . .	9
Always-on connector . . . . .	9
Rear view . . . . .	10
Air vents (outlet) . . . . .	10
Bottom view . . . . .	11
Air vents (intake) . . . . .	11
Speakers . . . . .	11
Novo button hole . . . . .	11
Features and specifications . . . . .	12
Statement on USB transfer rate . . . . .	14
Operating environment . . . . .	15

## Chapter 2. Get started with your computer . . . . .16

Your PC and its operating system . . . . .	16
Initial setup of the Windows operating system . . . . .	16
Set up facial recognition . . . . .	16

Enroll your fingerprints . . . . .	16
Windows Update . . . . .	17
Windows recovery options . . . . .	17
Use power efficiently . . . . .	18
Shut down your PC . . . . .	18
Put your PC into sleep mode . . . . .	18
Rechargeable battery pack . . . . .	18
Set power button behavior . . . . .	19
Adjust timeout settings for saving power . . . . .	20
System operation modes . . . . .	20
Adjustable display refresh rate (for selected models) . . . . .	21
Connect to a network . . . . .	21
Connect to a Wi-Fi network . . . . .	21
Establish a wired connection . . . . .	21
Unique Lenovo apps . . . . .	22
Lenovo Vantage . . . . .	22
Smart Connect . . . . .	22
Smart Note . . . . .	23
Lenovo AI Now . . . . .	24
Use your Yoga in various modes . . . . .	24

## Chapter 3. Explore your computer . . . 27

Intelligent features . . . . .	27
Eye Care Mode . . . . .	27
Presence Detection (for selected models) . . . . .	27
Super Resolution (for selected models) . . . . .	27
Smart Noise Cancelling . . . . .	28
Dolby Atmos . . . . .	28
Interact with your computer . . . . .	29
Hotkeys . . . . .	29
The fn lock switch . . . . .	30
Combination keys using the fn key . . . . .	31
Combination keys using the Windows logo key . . . . .	31
The Copilot key . . . . .	32
Touchpad gestures . . . . .	32
Touch operations supported by Windows . . . . .	34
Connect to an external display . . . . .	35
Turn on night light . . . . .	36
Protect your privacy using the camera shutter . . . . .	37
The Novo Button menu . . . . .	37
Open the Novo Button menu . . . . .	37
Set passwords in UEFI/BIOS setup utility . . . . .	38
Password types . . . . .	38
Set administrator password . . . . .	38

Change or remove administrator password . . . . .	38
Set user password . . . . .	39
Enable power-on password . . . . .	39
Set hard disk password . . . . .	39
Change or remove hard disk password . . . . .	40
Change settings in UEFI/BIOS setup utility . . . . .	40
What is UEFI/BIOS setup utility . . . . .	40
Open the UEFI/BIOS setup utility . . . . .	40
Select boot devices . . . . .	40
Change hotkey mode. . . . .	41
Enable or disable always-on . . . . .	41
Enable or disable Flip to Start . . . . .	41
<b>Chapter 4. Accessories . . . . .</b>	<b>42</b>
Lenovo Yoga Pen . . . . .	42
Pen settings . . . . .	43
Lenovo TWS YOGA PC Edition . . . . .	43
<b>Chapter 5. Help and support . . . . .</b>	<b>44</b>
Frequently asked questions . . . . .	44
Where can I get the latest device drivers and UEFI/BIOS . . . . .	44
What should I do if my computer stops responding . . . . .	44
What should I do if I spill liquid on the computer . . . . .	44
Why does my computer start automatically when I open the lid . . . . .	44
Why does my screen brightness change constantly . . . . .	44
What should I do if I cannot connect to the network . . . . .	44
What should I do with blue screen errors . . . . .	45
What should I do if the screen flickers . . . . .	45
What should I do if my touchpad does not respond . . . . .	45
What should I do if the audio does not work . . . . .	46
What should I do if my camera can't be launched or found . . . . .	46

What should I do if my keyboard does not work . . . . .	47
What should I do if my keyboard backlight does not work. . . . .	47
How to reset my Windows password. . . . .	48
What should I do if the built-in battery cannot be charged. . . . .	48
Self-help resources . . . . .	48
What is a CRU?. . . . .	49
CRUs for your product model . . . . .	50
Call Lenovo . . . . .	50
Before you contact Lenovo . . . . .	50
Lenovo Customer Support Center . . . . .	51
Purchase additional services. . . . .	51

**Chapter 6. PC and accessibility . . . . . 52**

Accessibility features of the PC hardware . . . . .	52
USB connectors for connecting assistive technology devices . . . . .	52
Keyboard accessibility . . . . .	52
Biometric devices . . . . .	53
Accessibility features of Windows 11 . . . . .	53
Configuring accessibility features in the Settings app . . . . .	54
Narrator . . . . .	54
Adjusting text sizes, applying a high-contrast theme, and using Magnifier . . . . .	54
Sticky Keys. . . . .	55
Accessible user documentation . . . . .	55
Accessibility features of user documentation . . . . .	55
Testing documentation accessibility . . . . .	56

**Appendix A. Important notice for Quebec consumers . . . . . 57**

**Appendix B. Notices and trademarks. . . . . 58**

---

## About this guide

- This guide applies to Lenovo product model(s) listed below. Illustrations in this guide may look slightly different from your product model.

Model name	Machine type (MT)
<ul style="list-style-type: none"><li>– Yoga 7 2-in-1 14ILL10</li><li>– Yoga 7 2-in-1 14ILL10 1</li></ul>	83JQ
<ul style="list-style-type: none"><li>– Yoga 7 2-in-1 14AKP10</li><li>– Yoga 7 2-in-1 14AKP10 1</li></ul>	83JR
<ul style="list-style-type: none"><li>– Yoga 7 2-in-1 16ILL10</li><li>– Yoga 7 2-in-1 16ILL10 1</li></ul>	83JT
Yoga 7 2-in-1 16AKP10	83JU

- For further compliance information, refer to the *Generic Safety and Compliance Notices* at [https://pcsupport.lenovo.com/docs/generic\\_notices](https://pcsupport.lenovo.com/docs/generic_notices).
- This guide may contain information about accessories, features, and software that are not available on all models.
- This guide contains instructions that are based on the Windows operating system. These instructions are not applicable if you install and use other operating systems.
- Microsoft® makes periodic feature changes to the Windows® operating system through Windows Update. As a result, the operating system related instructions may become outdated. Refer to Microsoft resources for the latest information.
- The content of the guide is subject to change without notice. To obtain the latest version, go to <https://support.lenovo.com>.

---

# Chapter 1. Meet your computer

---

## Front view

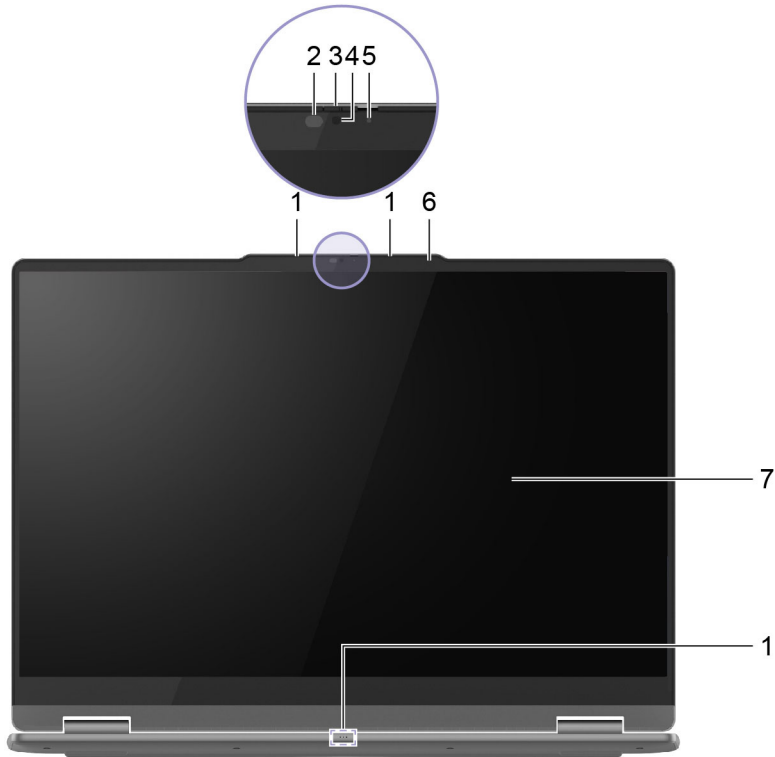

Figure 1. Front view (for models with FHD IR camera)

No.	Description
1	Microphones
2	Infrared LED
3	Camera shutter
4	Camera
5	Camera light
6	Ambient light sensor
7	Screen

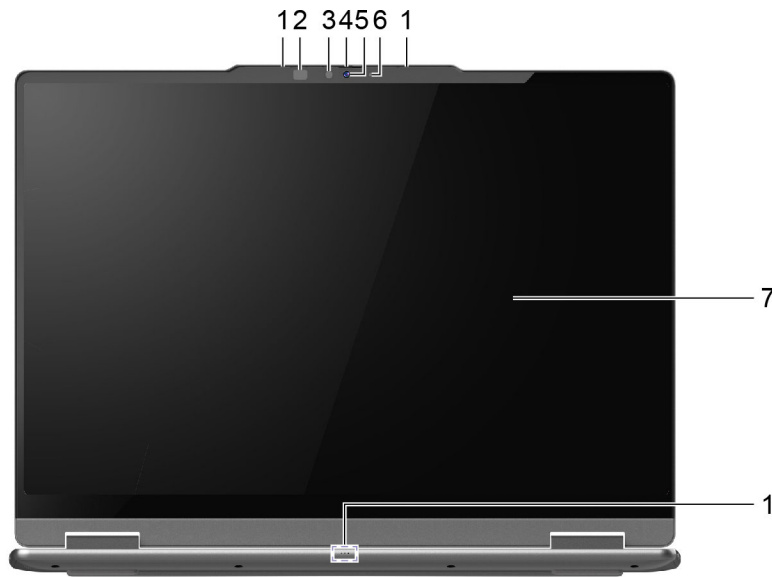

Figure 2. Front view (for models with 5MP IR camera)

No.	Description
1	Microphones
2	Infrared LED
3	Infrared camera
4	Camera shutter
5	Camera
6	Camera light
7	Screen

## Microphones

The microphones are the PC's built-in sound input devices. They capture your voice and ambient sound and convert them into digital form. Microphones are essential components when you use your PC for video conferencing or voice recording.

## Infrared LED

The infrared LED generates and emits near-infrared waves that are received and used by a camera (or a dedicated infrared camera) for facial recognition.

## Infrared camera

The infrared camera receives near-infrared waves emitted by an infrared LED and reflected by a human face. It is used for facial recognition.

## Camera shutter

The camera shutter is a sliding cap that you can move to block the camera lens.

**Notes:** The camera shutter is designed for privacy protection. When the camera lens is blocked:

- The RGB camera function is disabled.

- Human presence detection and ambient light sensing functions are unavailable (for selected models).

## Camera

The built-in camera captures visible light and converts it to digital signals. It is used for video recording and video conferencing.

For models with FHD IR camera, this camera also receives near-infrared waves emitted by an infrared LED and reflected by a human face, so it can also be used for facial recognition.

## Camera light

The camera light indicates whether the camera is activated.

*Table 1. Camera light status and description*

Camera light status	Description
On	The camera is activated.
Off	The camera is not activated.

## Ambient light sensor

The ambient light sensor detects and measures the intensity of light in the user's environment. The data collected by this sensor can be used to enable adaptive brightness for the PC's built-in display and keyboard.

## Screen

The screen of the built-in display is where text, graphics, and videos are displayed.

The screen is touch-enabled, allowing you to interact with your PC by intuitively touching buttons, icons, and menu items displayed on the screen. Touch-enabled screens also support multi-finger gestures.

## Top view

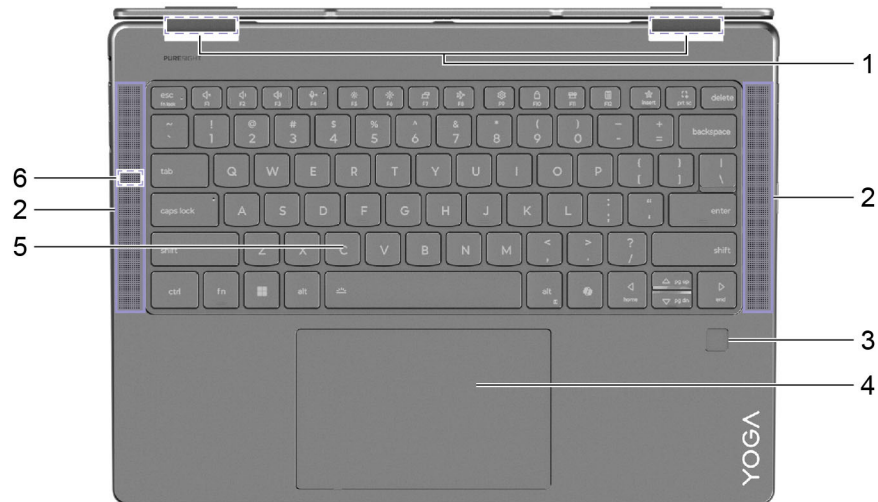

Figure 3. 14-inch models—Top view



Figure 4. 16-inch models—Top view

No.	Description
1	Antennas (cannot be seen from the outside)
2	Speakers
3	Fingerprint sensor*
4	Touchpad
5	Keyboard
6	Microphone

\* for selected models

## Antennas

The antennas transmit and receive radio waves to allow data to be transferred between your PC and a Wi-Fi network device or a Bluetooth device.

**Note:** The antennas are hidden inside the PC.

## Speakers

The speakers are the PC's built-in sound output devices.

## Fingerprint sensor

The fingerprint sensor scans your finger to unlock your PC or verify your identity.

**Note:** You need to enroll one or more fingerprints before using them for identity verification. On a Windows PC, go to **Settings** → **Accounts** → **Sign-in options** to enroll your fingerprints.

## Touchpad

The touchpad is the PC's built-in pointing device, which provides the basic functionality of an external mouse. Slide your finger on the touchpad to move the pointer on the screen and tap or double-tap to select or execute a screen item.

The touchpad also supports Windows multi-finger gestures, which provide shortcuts to frequently used apps and functions.

## Keyboard

The keyboard is the primary input device for a PC, designed for typing characters. A Lenovo keyboard also includes shortcut keys that enhance productivity when interacting with the PC, applications, and the Windows operating system.

**Note:** Keyboard layouts vary by language and region, so your PC's keyboard may differ from the illustrations in this publication.

## Microphones

The microphones are the PC's built-in sound input devices. They capture your voice and ambient sound and convert them into digital form. Microphones are essential components when you use your PC for video conferencing or voice recording.

## Left view

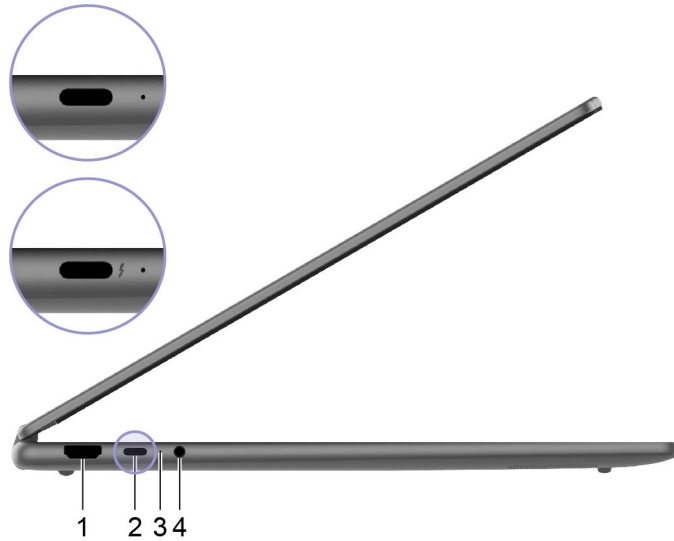

Figure 5. Left view

No.	Description
1	HDMI™ connector
2	Multi-purpose USB Type-C® connector
3	Charging light
4	Combo audio jack

## HDMI connector

The HDMI connector is used to connect an external display device, such as a television, a projector, or a monitor.

## Multi-purpose USB Type-C connector

Use the included power adapter and this connector to supply power to the PC.

When this connector is not used by the included power adapter, it can also be used to connect:

- Storage or peripheral devices that follow the universal serial bus (USB) specification for data transfer and device interconnection
- Display devices

**Note:** When connecting display devices, you need to use appropriate cables and adapters (if needed) according to the connection capabilities of the display device.

- Thunderbolt™-enabled docks or devices (for the connector with ⚡)

## Charging light

The charging light indicates whether the PC is plugged into an electrical outlet. When the PC is plugged into an electrical outlet, the color of the light indicates whether the battery is fully charged (or will shortly be fully charged).

Table 2. Charging light status and description

Light status	Plugged in?	Battery charge level
Off	No	/
On, amber	Yes	1%–90%
On, white	Yes	91%–100%

## Combo audio jack

The combo audio jack is used to connect single-plug headsets, headphones, or external speakers.

## Right view

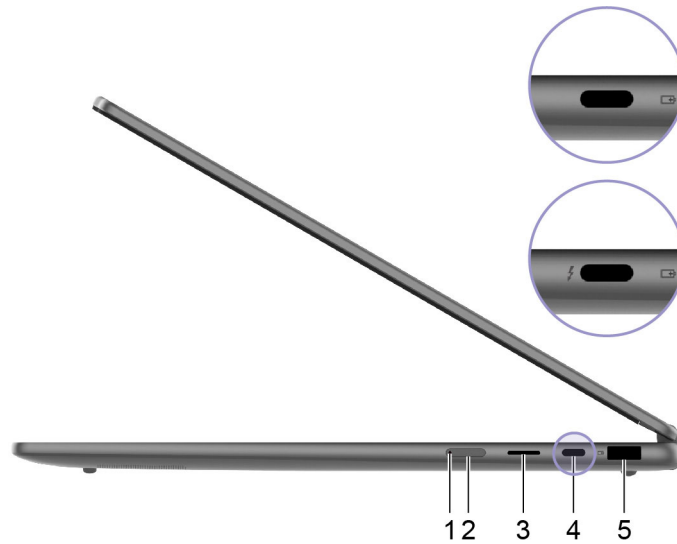

Figure 6. Right view

No.	Description
1	Power light
2	Power button
3	microSD card slot
4	Multi-purpose USB Type-C connector
5	USB Standard-A connector (always-on)

## Power light

The power light indicates the current power state of the PC: whether it is powered on, powered off, in sleep mode, or in hibernation mode.

When the PC is powered on, this light can also indicate low battery by blinking rapidly.

Table 3. Power light status and description

Light status	Power state	Battery charge level
White (solid on)	Powered on	21%–100%
White (blinking rapidly)	Powered on	1%–20%
White (blinking slowly)	In sleep mode	/
Off	Powered off or in hibernation mode	/

## Power button

Press the power button to turn on your PC.

**Note:** By default, on a Windows PC, pressing the power button when the PC is turned on will put the PC into sleep mode.

## microSD card slot

The microSD card slot is used to insert a microSD, microSDHC, or microSDXC memory card to transfer data between the memory card and your PC.

## Multi-purpose USB Type-C connector

Use the included power adapter and this connector to supply power to the PC.

When this connector is not used by the included power adapter, it can also be used to connect:

- Storage or peripheral devices that follow the universal serial bus (USB) specification for data transfer and device interconnection
- Display devices

**Note:** When connecting display devices, you need to use appropriate cables and adapters (if needed) according to the connection capabilities of the display device.

- Thunderbolt™-enabled docks or devices (for the connector with )

## USB Standard-A connector

The USB Standard-A connector is used to connect storage or peripheral devices that follow the universal serial bus (USB) specification for data transfer and device interconnection.

## Always-on connector

A USB connector with a battery icon () supports the always-on function. The PC can supply power to a USB device connected to this type of connector even when the PC is powered off, in sleep mode, or in hibernation mode.

The always-on function can be turned on and off in:

- The PC's firmware setup utility, or
- Lenovo Vantage or Lenovo PC Manager

---

## Rear view

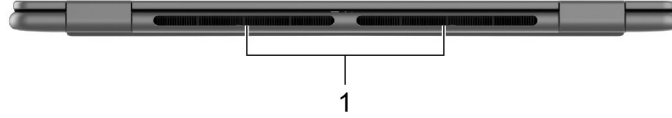

Figure 7. Rear view

No.	Description
1	Air vents (outlet)

## Air vents (outlet)

The air vents allow hot air to be discharged out of the PC.

**Important:** When the PC is operating, do not place it on a bed, sofa, carpet, or other flexible surfaces. Otherwise, the air vents will be blocked and the PC may overheat, reducing performance or causing the PC to be unresponsive or even shut down.

## Bottom view

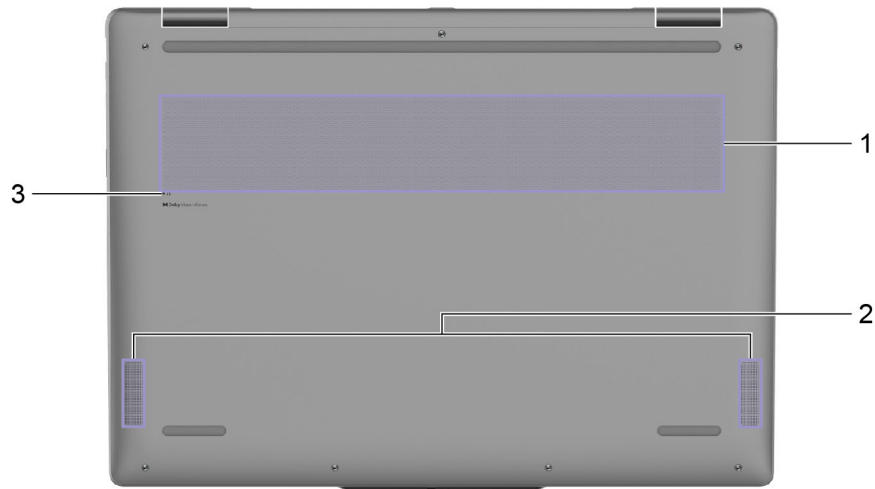

Figure 8. Bottom view

No.	Description
1	Air vents (intake)
2	Speakers
3	Novo button hole

## Air vents (intake)

The air vents allow air to be sucked inside of the PC to cool the internal components.

**Important:** When the PC is operating, do not place it on a bed, sofa, carpet, or other flexible surfaces. Otherwise, the air vents will be blocked and the PC may overheat, reducing performance or causing the PC to be unresponsive or even shut down.

## Speakers

The speakers are the PC's built-in sound output devices.

## Novo button hole

When the PC is powered off, you can press the Novo button to display the Novo button menu. From the menu, you can then choose to:

- Open the firmware setup utility
- Display the boot device selection menu
- Display the Windows advanced startup options page

**Note:** The Novo button is rarely used during normal PC operations. To prevent users from accidentally pressing it, the Novo button is placed in a recessed hole. You can use a straightened paper clip to press this button.

---

## Features and specifications

### Dimensions (14-inch models)

Item	Value or specification
Width	317 mm
Depth	228 mm
Thickness (Aluminium)	T2-T4: 15.45-16.49 mm
Thickness (Silicon)	T2-T4: 15.95-16.99 mm

### Dimensions (16-inch models)

Item	Value or specification
Width	361 mm
Depth	257 mm
Thickness	T2-T4: 15.85-16.99 mm

### ac power adapter

Item	Value or specification
Input	100 V ac–240 V ac, 50 Hz–60 Hz
Output voltage	20 V
Maximum output current	3.25 A
Maximum output power	65 W

### Rechargeable battery pack

Item	Value or specification
Capacity	70 Wh
Cell type	Lithium-polymer
Number of cells	4

**Note:** The battery capacity is the typical or average capacity as measured in a specific test environment. Capacities measured in other environments may differ but are no lower than the rated capacity (see product label).

### Memory

Item	Value or specification
Type	LPDDR5X
Number of slots	0

## Mass storage device

Item	Value or specification
Type	Solid-state drive (SSD)
Slot type	M.2 (2242)
Number of slots	1
Interface	PCIe Gen4

## Display

**Note:** Depending on your computer model, your computer should only support one of the screen sizes/resolutions/maximum refresh rates listed below.

Item	Value or specification
Screen size (diagonal)	<ul style="list-style-type: none"><li>• 14 inches</li><li>• 16 inches</li></ul>
Resolution	<ul style="list-style-type: none"><li>• 2880 × 1800</li><li>• 1920 × 1200</li></ul>
Maximum refresh rate	<ul style="list-style-type: none"><li>• 60 Hz</li><li>• 120 Hz</li></ul>

## Connectors and slots

Item	Value or specification
USB Standard-A connector	<ul style="list-style-type: none"><li>• Quantity: 1</li><li>• Maximum power output: 5 V, 1.5 A</li><li>• Supported signaling protocols:<ul style="list-style-type: none"><li>– USB 2.0 480 Mbps</li><li>– SuperSpeed USB 5 Gbps</li></ul></li></ul>
Multi-purpose USB Type-C connector (Yoga 7 2-in-1 14AKP10, Yoga 7 2-in-1 16AKP10)	<ul style="list-style-type: none"><li>• Quantity: 2</li><li>• Maximum power output: 5 V, 3 A</li><li>• Maximum power input: 20 V, 3.25 A</li><li>• Supported signaling protocols:<ul style="list-style-type: none"><li>– USB 2.0 480 Mbps</li><li>– SuperSpeed USB 5 Gbps</li><li>– SuperSpeed USB 10 Gbps</li><li>– DisplayPort 1.4a</li></ul></li></ul>

Item	Value or specification
Multi-purpose USB Type-C connector (Yoga 7 2-in-1 14ILL10, Yoga 7 2-in-1 16ILL10)	<ul style="list-style-type: none"> <li>• Quantity: 2</li> <li>• Maximum power output: 5 V, 3 A</li> <li>• Maximum power input: 20 V, 3.25 A</li> <li>• Supported signaling protocols: <ul style="list-style-type: none"> <li>– USB 2.0 480 Mbps</li> <li>– SuperSpeed USB 5 Gbps</li> <li>– SuperSpeed USB 10 Gbps</li> <li>– DisplayPort 2.1</li> <li>– Thunderbolt 4 41.25 Gbps</li> </ul> </li> </ul>
HDMI™ connector	Supported signaling protocols: Transition minimized differential signaling (TMDS)
Combo audio jack	<ul style="list-style-type: none"> <li>• Diameter: 3.5 mm</li> <li>• Supported plug: <ul style="list-style-type: none"> <li>– 3-pole, TRS</li> <li>– 4-pole, TRRS (CTIA and OMTP)</li> </ul> </li> </ul>
microSD slot	Supported card types: <ul style="list-style-type: none"> <li>• microSD card</li> <li>• microSDHC card</li> <li>• microSDXC card</li> </ul>

**Note:** Data rates and performance ratings are dependent on connected devices and cables if they are used. USB Type-C connectors that are DisplayPort 2.1 compliant through DisplayPort alternate mode provide maximum output resolution of 7680 x 4320, at 60 Hz frame rate and color depth of 36 bpp (bits per pixel). The actual maximum output resolution is dependent on the connected display device and the cable being used.

## Networking

Item	Value or specification
Wi-Fi®	Wi-Fi 7 <b>Note:</b> Different Wi-Fi standards may operate on different frequency bands. In some countries or regions, certain frequency bands may be prohibited for unlicensed use or may require specific conditions. Wi-Fi 7 on this PC are disabled in some countries or regions in accordance with local regulations.
Bluetooth®	Bluetooth 5.4

## Statement on USB transfer rate

Depending on many factors such as the processing capability of the host and peripheral devices, file attributes, and other factors related to system configuration and operating environments, the actual transfer rate using the various USB connectors on this device will vary and will be slower than the data rate listed below for each corresponding device.

USB device	Data rate (Gbit/s)
3.2 Gen 1	5
3.2 Gen 2	10

# Operating environment

## Maximum altitude (without pressurization)

3048 m (10 000 ft)

## Temperature

- At altitudes up to 2438 m (8000 ft)
  - Operating: 5°C to 35°C (41°F to 95°F)
  - Storage: 5°C to 43°C (41°F to 109°F)
- At altitudes above 2438 m (8000 ft)
  - Maximum temperature when operating under the unpressurized condition: 31.3°C (88°F)

**Note:** When you charge the battery, its temperature must be no lower than 10°C (50°F).

## Relative humidity

- Operating: 8% to 95% at wet-bulb temperature 23°C (73°F)
- Storage: 5% to 95% at wet-bulb temperature 27°C (81°F)

---

## Chapter 2. Get started with your computer

---

### Your PC and its operating system

The operating system is essential software for a PC. It manages the hardware devices of the PC, provides utility applications and user interfaces, and enables the installation of various applications for a wide range of purposes.

Your PC comes with Windows 11 pre-installed.

### Initial setup of the Windows operating system

When you turn on your PC for the first time, the Windows operating system will guide you through the initial setup process. Most importantly, you will:

- Create a user account
- Connect to a wireless network that has Internet access
- Select language-related settings

**Note:** If you choose to set up Windows for personal use, you must either use an existing Microsoft account or create a new one. You can switch to a local account after the initial setup.

### Set up facial recognition

Apart from text-based passwords, Windows 11 supports additional user authentication methods for PCs with the required hardware devices. For PCs equipped with a built-in infrared LED and an infrared camera, you can enable facial recognition to sign into Windows using your face.

Step 1. Select **Start → Settings → Accounts → Sign-in options → Facial recognition**.

Step 2. Select **Set up → Get started** and follow on-screen instructions to enroll your face.

**Note:** If you are using a local account to sign into Windows, you must set a password for the account before you can enable facial recognition.

### Enroll your fingerprints

You can use the biometric fingerprint option to sign in to Windows quickly if your computer includes a fingerprint sensor. This sign-in option provides a reliable and secure way of identity verification.

Step 1. Select **Start → Settings → Accounts → Sign-in options**.

Step 2. Under **Ways to sign in**, select **Fingerprint recognition (Windows Hello)** to set up sign-in with a fingerprint sensor.

Step 3. Follow the on-screen instructions to enroll your fingerprints.

**Notes:**

- You need to set up a PIN code before you are allowed to use this sign-in option.
- It is recommended that you enroll multiple fingerprints in case of any injuries to your fingers.

## Windows Update

From time to time, your PC receives update notifications. These notifications may include new features, security updates, and device drivers. While security-related updates are typically downloaded and installed automatically, you can manually control the installation of other available updates.

In Windows Update, you can view available updates, manually check for updates, and configure settings related to updates. To navigate to Windows Update, select **Settings → Windows Update**.

## Windows recovery options

While using your PC, you may encounter various issues. Windows provides several recovery options to help restore your system to normal functionality. The table below will help you choose the right option for different situations.

Table 4. Windows recovery options

Situations	Recovery options
Windows runs much slower after you install an app.	Restore Windows from a system restore point.
Windows hasn't been functioning properly for some time.	Reset your PC while keeping your personal files.
Your PC won't start.	Utilize Windows startup repair function.
Your PC won't start and cannot be repaired using Windows startup repair function.	Use a recovery drive to restore Windows.

## Reset Windows

Resetting Windows allows you to reinstall the operating system while retaining your personal files. This gives the operating system a fresh start and, in some cases, restores the PC's original performance.

- Step 1. Select **Settings → System → Recovery**.
- Step 2. Under recovery options, select **Reset PC**.  
When prompted, choose between **Keep my files** and **Remove everything**.
- Step 3. Follow the on-screen instructions to complete the reset process.

## Create a recovery drive

It is advisable to create a recovery drive after completing the initial setup of Windows. If you encounter a significant issue that prevents Windows from starting, you can use the recovery drive to restore the operating system on your PC.

- Step 1. Prepare an empty USB drive with a storage capacity of 32 GB or more.
- Step 2. In the search box on the taskbar, type *Create a recovery drive* and select the matched app.
- Step 3. Make sure **Back up system files to the recovery drive** checkbox is selected and select **Next**.
- Step 4. When prompted, connect the USB drive to your PC, select it, and then select **Next**.
- Step 5. Select **Create**.

## Restore Windows using a recovery drive

If the Windows operating system fails to start, you can use a previously created recovery drive to restore Windows onto your PC.

- Step 1. Shut down your PC.
- Step 2. Connect the recovery drive to your PC.
- Step 3. Press the Novo button or the Lenovo Smart Key ☆ to open the Novo button menu.
- Step 4. Select **Boot Menu**.
- Step 5. Select the USB drive as the boot device.  
The PC will start to the Windows Recovery Environment.
- Step 6. Follow the on-screen instructions to restore Windows onto your PC.

---

## Use power efficiently

Use the power management features in this section to achieve the best balance between performance and power efficiency.

### Shut down your PC

When you have finished using your PC and do not plan to resume shortly, shut it down.

- Step 1. Select **Start → Power**.
- Step 2. Select **Shut down**.

### Put your PC into sleep mode

If you need to stop using your PC but plan to resume shortly, you can put it into sleep mode. Your PC will wake up more quickly from sleep mode, allowing you to return to where you left off with your work.

- Step 1. Select **Start → Power**.
- Step 2. Select **Sleep**.

### Rechargeable battery pack

Your computer includes a built-in, rechargeable battery pack that makes mobile computing a reality. When the computer is plugged into an electrical outlet, the battery charges. If you use the computer when you don't have access to an electrical outlet, the battery discharges to supply electricity that the computer system requires for operation.

You can charge the battery any time you want. The battery packs of Lenovo computers support multiple charging modes that are suitable for different power usage habits. You can switch the battery's active charging mode in Lenovo Vantage or Lenovo PC Manager.

Battery charging is also affected by its temperature. The recommended temperature range for charging the battery is between 10°C (50°F) and 35°C (95°F).

#### Note:

You can check the battery temperature in Lenovo Vantage.

To maximize the life of the battery, once the battery is fully charged, it must discharge to 94% or lower before it will be allowed to recharge again.

## Normal mode

Normal mode is the most basic charging mode. In normal mode, it typically takes 2 to 4 hours for the battery to charge from 0% to 100%.

## Rapid charge mode

If you want the battery to be charged faster than in normal mode, switch the battery charging to rapid charge mode.

## Conservation mode

If your computer is constantly plugged into an electrical outlet, consider switching the battery charging to conservation mode. In conservation mode, the battery will not be fully charged. Instead, the battery's charge will be kept within 75%–80%. This is beneficial to the long-term health of the battery.

**Note:** If you want the battery to be fully charged before bringing the computer to work, disable conservation mode by switching the battery charging to normal or rapid charge mode.

## Overnight battery charging mode

Some people follow a regular pattern when using their computers. They finish their workday with the computer at a low battery charge level. They plug in their computers at night and need the battery to be fully charged the next morning so they can unplug the computer and bring it to work. These activities happen at approximately the same time each day. If this sounds like you, consider enabling overnight battery charging mode for the battery.

Overnight battery charging mode affects battery charging during the night hours, the time when you're usually asleep. When it is enabled, the computer regularly adapts its charging behavior based on observation of when you plug in the computer at night and unplug it in the morning. During the nighttime, the battery is charged to a particular range and is kept within that range for an extended period, before being further charged to 100%. Overnight battery charging mode ensures safe charging during the night and is beneficial to the long-term health of the battery.

**Note:** With overnight battery charging mode enabled, if you break your routine one day by unplugging the computer much earlier than usual in the morning, you may find that the battery is not fully charged.

If the battery pack of your computer supports overnight battery charging mode, it can be enabled in Lenovo Vantage or Lenovo PC Manager.

## Recover full battery capacity

If your computer is constantly plugged in to an electrical outlet and the battery rarely discharges, the battery may not be charged to its full capacity even if the battery meter reports 100% charge. You can recover the battery's full charging potential simply by discharging and re-charging the battery.

- Step 1. Unplug the computer and use it until the battery charge drops below 20%.
- Step 2. Plug in the computer and charge the battery to 100%.

## Set power button behavior

By default, pressing the power button puts the computer to sleep mode. However, you can change the power button behavior in Windows Control Panel.

- Step 1. Type Control Panel in the Windows search box and then press enter. Open the control panel and view by large or small icons.
- Step 2. Select the power options and then click choose what the power button does.

## Adjust timeout settings for saving power

Setting appropriate timeouts for your PC to enter sleep mode and for the built-in screen to turn off is an effective method of reducing your PC's power consumption. The Windows operating system comes with default timeout settings for these two items, which you can adjust to better suit your preferences.

Step 1. Select **Start → Settings → System → Power & battery → Screen, sleep, & hibernation timeouts**.

Step 2. Adjust the settings.

For notebook PCs, you can set distinct timeouts for two usage scenarios: when the PC is plugged in and when it is running on battery power.

### Default timeout settings for power saving

The operating system on your PC has the following timeouts enabled by default. You can adjust these settings to better suit your preferences.

**Note:** Setting appropriate timeouts is an effective method of reducing your PC's power consumption. Avoid setting excessively long timeouts to effectively disable this power-saving feature.

Table 5. Default timeout settings for the PC to enter sleep mode and the screen to turn off

Power saving action	Power state	Timeout (minute)
Turn off the screen	Plugged in	5
	On battery	3
Put the PC into sleep mode	Plugged in	5
	On battery	3

**Note:** To wake the PC from sleep mode, press the power button or any key on the keyboard.

## System operation modes

Lenovo has preset several modes in which your computer can operate. The maximum attainable performance, power consumption, and speed limit for the heat sink fan vary between the operation modes. Consider the following conditions when you want to switch operation modes.

- The environment where you use your computer, and
- The tasks running on your computer

You can switch the operation mode in the pre-installed app Lenovo Vantage or Lenovo PC Manager. As a shortcut, you can also use the key combination **fn + Q**. Three modes are usually available for most Lenovo computers. The following table lists the operation modes and the recommended conditions for each mode.

**Note:** The operation modes listed in the table are descriptive and may not be the same as those displayed by the app.

Table 6. Operation modes and their recommended usage conditions

Operation mode	Recommended conditions
High Performance	<ul style="list-style-type: none"><li>• Your computer is plugged into an electrical outlet.</li><li>• You want the best performance, and</li><li>• You don't care if the fan makes a little noise.</li></ul>
Auto (Balance)	You plan to frequently switch between different computer tasks over a period of time.
Power Saving (Quiet)	<ul style="list-style-type: none"><li>• Your computer is operating on battery power, or</li><li>• You want the computer to be as quiet as possible.</li></ul>

**Note:** In Auto (Balance) mode, the computer dynamically switches between High Performance mode and Power Saving (Quiet) mode depending on the tasks running on the computer.

## Adjustable display refresh rate (for selected models)

Your eyes might not notice it but the content displayed on the computer screen refreshes constantly. Display refresh rate refers to the number of times per second the screen content refreshes itself and is measured in hertz (Hz).

A refresh rate of 60 Hz is adequate for most situations and is energy efficient. However, when viewing videos or playing video games, a higher refresh rate usually provides a smoother viewing experience.

The displays of some Lenovo computers support dual refresh rates. For such a computer, you can manually switch its display to work at either the higher or lower refresh rate. For Windows operation systems, the manual settings are usually found in **Settings** → **System** → **Display**. As a shortcut, you can also use the key combination **fn + R** to switch the display refresh rate.

**Note:** Not all displays support dual refresh rates. If you cannot find settings to change the display refresh rate, the refresh rate of the display might be fixed or cannot be manually changed.

---

## Connect to a network

### Connect to a Wi-Fi network

Ensure that you have a secure Wi-Fi network account and the required credentials.

- Step 1. Select the network icon  on the bottom right of your display.
- Step 2. Select an available network, and then select **Connect**.  
If you want to be automatically connected to this Wi-Fi network the next time you start your computer, select **Connect automatically** before selecting **Connect**.
- Step 3. Input your credentials if necessary, and then follow the on-screen instructions to connect to the desired Wi-Fi network.

### Establish a wired connection

- Step 1. Plug an Ethernet cable into the Ethernet connector on your computer.
- Step 2. Plug the other end of the Ethernet cable into a network wall jack or a router.

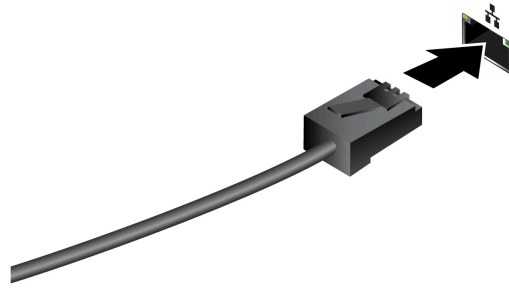

**Note:** If your computer does not include an Ethernet connector, you can purchase a USB-C to Ethernet adapter from Lenovo at <https://www.lenovo.com/accessories>.

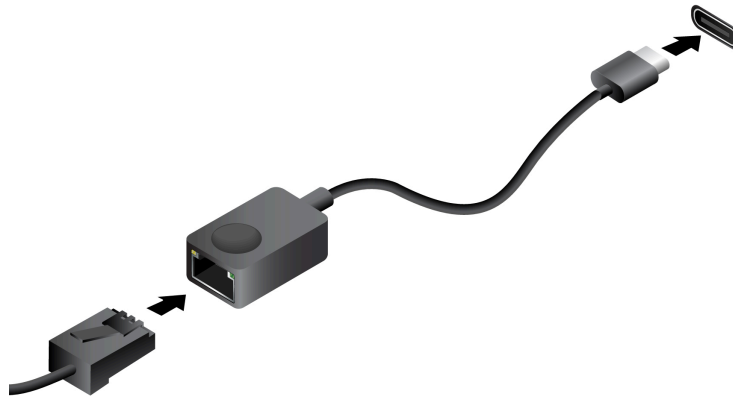

---

## Unique Lenovo apps

### Lenovo Vantage

Lenovo Vantage is a one-stop solution to help you update your computer, configure hardware settings, and access personalized support.

If your computer is pre-installed with Lenovo Vantage, type Vantage in the Windows search box to launch this app.

**Notes:**

- Available features may vary depending on your computer model.
- You can download the latest version of this app from Microsoft Store.

### Smart Connect

Smart Connect is an app that can easily pair your PC with your Motorola smartphone and Lenovo tablet. With Smart Connect, you can:

- Access mobile apps on your PC
- Quickly share content between connected devices
- Mirror your phone display or create a virtual phone screen on your PC
- Copy and paste across connected devices

- Use your phone or tablet camera as the PC webcam
- Control your phone or tablet using your PC keyboard and mouse
- Extend or mirror your PC display on the tablet

**Note:** Smart Connect makes periodic updates to keep improving your experience. Features may be added or modified after updates are installed.

To open Smart Connect, you can type Smart Connect in the Windows search box and then select the matched result. Alternatively, you can also press the hotkey marked with  (F11) as a shortcut.

## Smart Note

During meetings or business conversations, you may want to jot down important tips and flashes of inspiration. Additionally, you might need to include images, screenshots, or even audio recordings to help you remember the details later. The Smart Note app is designed for note-taking in a way that differs from traditional methods. If your PC comes with a Lenovo Yoga Pen (hereinafter referred to as “the pen” in this section), it is highly recommended that you use the pen to fully experience the convenience offered by Smart Note.

With the Smart Note app pre-installed on your PC, you can open this app by typing Smart Note in the Windows search box and selecting the matched result.

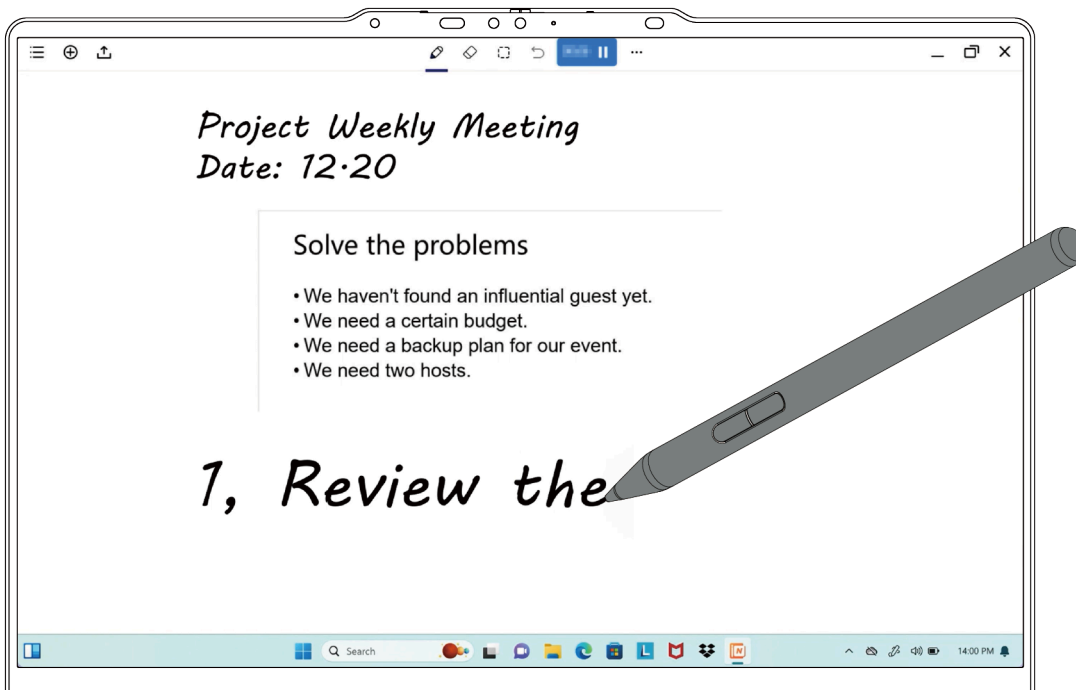

Table 7. Convenient functions of Smart Note

Function	Description
Lock Screen Notes	If the Lock Screen Notes function is enabled, you can open the Smart Note app by hovering the pen tip over the locked screen. <b>Note:</b> The Lock Screen Notes function can be enabled in a pop-up window or in Smart Note Settings.
Quick gestures	<ul style="list-style-type: none"> <li>• Swipe the pen tip from the lower-right corner of the PC screen to the center to open Smart Note.</li> <li>• Swipe the pen tip from the lower-left corner of the PC screen to the center to activate the screenshot function.</li> </ul>
Insert screenshot or image	With the intuitive UI, you can easily insert screenshots or images into your notes.
Add audio	Audio recordings can help recall the details by reconstructing the scene. Your notes will automatically synchronize with the original audio timeline.
Change theme	When creating a note, you can select your preferred background style from a variety of options.
Write with finger	If your pen is unavailable, you can also use a finger to take notes.

**Note:** Available functions are subject to change and may vary depending on your computer model. Refer to your actual product.

## Lenovo AI Now

Lenovo AI Now is your personal and private AI assistant. It enables you to boost your productivity by building your personal knowledge library, helps you with inspiration, writing and summarizing, and provides troubleshooting and quick settings for your PC.

To open Lenovo AI Now, type `Lenovo AI Now` in the Windows search box and select the matched result. Alternatively, you can also press the hotkey marked with ☆ as a shortcut.

### Notes:

- Lenovo AI Now is not available on all product models. For those models not pre-installed with this app, pressing the hotkey ☆ will open a quick launch panel.
- Lenovo AI Now makes periodic updates to keep improving your experience. Features may be added or modified after updates are installed.

## Use your Yoga in various modes

The screen of your computer can open up to an angle of 360 degrees, enabling you to use your computer for different purposes.

### Notes:

- Do not rotate the display with too much force, or apply too much force to the upper-right or upper-left corner of the display. Otherwise, the computer display or hinges might get damaged.
- The keyboard and the pointing device are automatically disabled in the stand mode, tent mode, and tablet mode. Use the touch screen to control your computer instead. The keyboard and the pointing device will be enabled again automatically when you switch from other modes to notebook mode.

---

**Mode**

Notebook mode

**Suitable for**

- Entering text
- Drag and drop operations using the touchpad

Stand mode

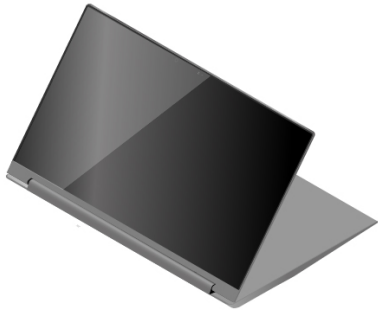

- Giving a presentation
- Viewing a slide show

---

**Mode**

Tent mode

**Suitable for**

Watching movies

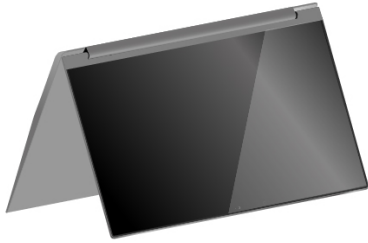

Tablet mode

Playing touch-enabled games



---

**Note:** Product illustrations in this section are used to demonstrate features that are supported by a range of Lenovo products. It is normal that they may look different from your product model.

---

## Chapter 3. Explore your computer

---

### Intelligent features

Your computer may be pre-installed with Lenovo Vantage or Lenovo PC Manager. Most features described here can be enabled or disabled in one of these apps. Other features may be enabled in a standalone app.

#### Notes:

- Software features are subject to change. Please refer to your actual product.
- You may need to complete online update to the apps for the features to take effect.

### Eye Care Mode

Eye Care Mode intelligently adjusts the color temperature of the screen and can reduce the chances of developing eye fatigue or eye strain.

### Presence Detection (for selected models)

Presence Detection enables you to improve work efficiency by automatically waking up and logging into your computer, or dimming the display and locking the computer depending on user detection.



For selected video players, this feature will pause any video playing when you leave the computer and resume upon your return.

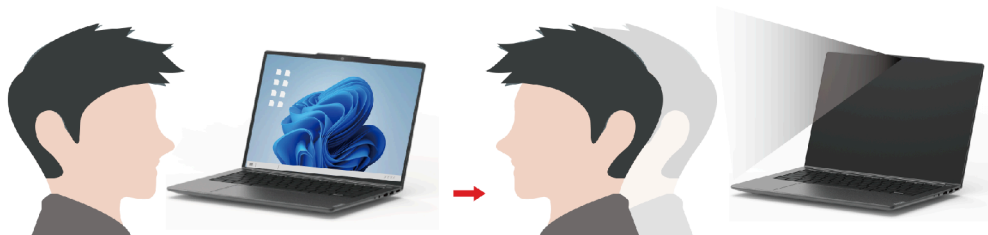

**Note:** Depending on your computer model, this feature may be unavailable when the camera lens is blocked.

### Super Resolution (for selected models)

By utilizing the capabilities and potentials of Intel processors, Super Resolution helps you play videos with a higher resolution than the original. It works especially well in cases where the source video has a poor resolution.

For most players, Super Resolution can be enabled or disabled in Lenovo Vantage or Lenovo PC Manager, but for some specific players, you might need to enable this feature manually.

## Smart Noise Cancelling

Smart Noise Cancelling is a noise reduction feature available on some Lenovo product models. By filtering out input and output noises, Smart Noise Cancelling enhances your audio experience.



Function	Description	Remarks
Microphone noise cancelling	<b>Voice Recognition:</b> Your computer captures multiple voices in a way that reflects their original spatial positions.	<ul style="list-style-type: none"> <li>This function takes effect only when built-in microphones/arrays or 3.5 mm jack wired microphones are used as the input media.</li> <li>To disable this function, select <b>Off</b>.</li> </ul>
	<b>Only My Voice:</b> This option requires you to record your voice so that your computer captures this voice only and tries to eliminate other voices. <b>Note:</b> To remove your voice record, select <b>REMOVE MY VOICE</b> .	
	<b>Normal:</b> Your computer focuses on the voice of the person facing it and reduces ambient sounds.	
	<b>Multiple Voices:</b> Your computer captures multiple voices from an expanded range in front of the computer.	
Speaker noise cancelling	Your computer filters out other sounds to play only human voices.	This function is not applicable to scenarios like listening to music and watching videos.

### Notes:

- Depending on its hardware, your computer may not support all the functions and options described above.
- You can view and customize this feature under **Device Settings** in Lenovo Vantage or Lenovo PC Manager.

## Dolby Atmos

If your PC is preinstalled with Dolby Atmos, you can set or define Dolby profiles in Lenovo Vantage or Lenovo PC Manager.

Dolby Atmos includes a set of fine-tuned audio processing parameters. You can select a profile that best suits your needs and adjust the profile settings if applicable.

Available profiles are described in the table below.

Table 8. Available profiles for Dolby Atmos

Profile	Description
Dynamic	Dolby technology identifies the content type and performs automatic adjustments.
Movie	Virtualized surround sound and clearer dialogues help you attend to every detail of the story.
Music	Rich, detailed audio optimized for music.
Game	Distinct sound placement makes it easier to locate sounds from any angle.
Voice	Enhances clear and consistent voice quality for virtual meetings and calls.
Custom	More flexibility is available with the audio processing settings. <b>Note:</b> You can create multiple custom profiles to best suit your needs for different scenarios.

## Interact with your computer

### Hotkeys

Hotkeys provide quick access to frequently used settings and applications. Typically located in the top row of the keyboard, they often share keys with the function keys (F1–F12) and several other keys. Each hotkey's function is denoted by the icon printed on the key. The keyboard of your computer may only support a subset of the listed hotkeys.

Table 9. Hotkey functions

















Hotkey icon	Function description
	Mutes/Unmutes sound.
	Decreases volume.
	Increases volume.
	Enables/Disables the microphone.
	Decreases screen brightness.
	Increases screen brightness.
	Selects and sets up display devices.
	Enables/Disables airplane mode.
	Opens the Settings app.
	Locks the screen.
	Opens the Smart Connect app.
	Opens the Calculator app.
	Opens Lenovo AI Now app or a quick launch panel.
	Opens the Snipping tool.
	Starts/Pauses audio or video playback.
	Stops audio or video playback.

Table 9. Hotkey functions (continued)

Hotkey icon	Function description
◀	Plays the previous audio or video in the playlist.
▶	Plays the next audio or video in the playlist.

## The fn lock switch

The fn lock is an electronic switch that affects how you use hotkey functions. To turn it on and off, press fn + esc.

**Note:** The esc key is in the upper left corner of the keyboard. It has an LED that indicates the status of the fn lock switch.

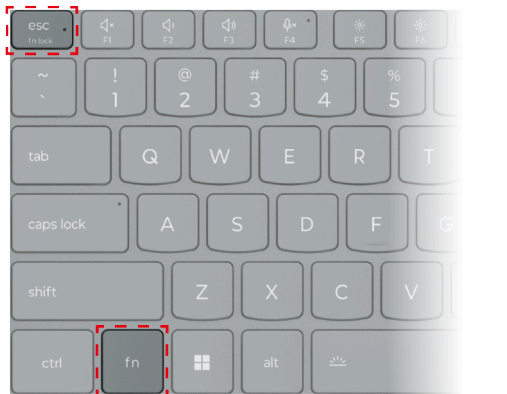

Figure 9. Locations of the fn lock key and the fn key

A Lenovo keyboard usually contains hotkeys in the top row. These hotkeys share keys with the function keys (F1–F12) and other keys. For these dual-function keys, the icons or characters denoting the primary functions are printed on top of the icons and characters denoting the secondary functions.

- A: an icon or character denoting the primary function
- B: an icon or character denoting the secondary function

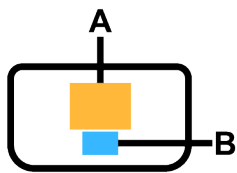

Figure 10. The layout of a dual-function key

Table 10. **fn lock** and dual-function keys

fn lock (esc) LED	fn lock status	Pressing the hotkey alone	Pressing the hotkey while holding down the fn key
Off	Disabled	Primary function	Secondary function
On	Enabled	Secondary function	Primary function

## Combination keys using the fn key

The fn key can be used in combination with specific keys to adjust device settings or activate additional functions.

Table 11. fn-based key combinations

Key combination	Function
fn + Q	Switches the PC's active power mode
fn + R*	Switches the refresh rates of the built-in display
fn + M	Enables/disables the touchpad
fn + N	Shows key device information
fn + Space	Adjusts keyboard backlight
fn + B	Break
fn + P	Pause
fn + S	SysRq
fn + K	ScrLk
fn + I	Insert
fn + T	PrtScr
fn + left arrow	Home
fn + right arrow	End
fn + up arrow	PgUp
fn + down arrow	PgDn

\* for selected models

## Combination keys using the Windows logo key

The Windows logo key is located in the lower-left corner of the keyboard. It can be used alone or in combination with specific keys to quickly change settings and access utilities within the Windows operating system. The table below lists frequently used key combinations. For a complete list of all key combinations that utilize the Windows logo key, please refer to the official Microsoft online documentation.

Table 12. Windows logo key combinations



Key or key combination	Function
Windows logo key 	Opens or closes the Start menu
+ A	Opens or closes Quick Settings
+ D	Returns to the desktop
+ E	Opens File Explorer
+ I	Opens Settings
+ L	Locks the screen
+ M	Minimizes all open windows
+ N	Opens or closes the Notification Area

Table 12. Windows logo key combinations (continued)

Key or key combination	Function
+ P	Switches multi-screen modes
+ W	Opens or closes Widgets
+ ; (semicolon)	Opens the emoji panel
+ Tab	Opens or closes Task View
+ PrtSc	Takes a full-screen screenshot and saves it to a file

## The Copilot key

The era of AI has arrived, and many Lenovo PCs now include a Copilot key on the keyboard. It is located either in the bottom or the top row of the keyboard and is marked with .

For Windows PCs with Copilot in Windows available and enabled, pressing the Copilot key opens Copilot in Windows. Otherwise, pressing the Copilot key opens Windows Search.

**Note:** Copilot in Windows may not be available in all geographical locations. In regions where Copilot in Windows is available, you may need to update your Windows operating system to version 23H2 or later through Windows Update for Copilot in Windows to become available.

## Touchpad gestures

The touchpad is your PC's built-in pointing device. You can tap and swipe on the touchpad to navigate within the operating system and within apps. In addition, the Windows operating system also supports multi-finger gestures on the touchpad to enhance productivity while interacting with the operating system.

Table 13. Multi-finger touchpad gestures

Gesture	Function
Swipe vertically with two fingers 	Scrolls pages
Place two fingers on the touchpad and pinch in or stretch out 	Zooms out / zooms in

Table 13. Multi-finger touchpad gestures (continued)

Gesture	Function
<p data-bbox="167 275 513 302">Tap two fingers on the touchpad</p> 	<p data-bbox="808 275 1247 302">Displays the context menu (right-clicking)</p>
<p data-bbox="167 569 610 596">Swipe up with three fingers or four fingers</p> 	<p data-bbox="808 569 1068 596">Shows all open windows</p>
<p data-bbox="167 858 643 886">Swipe down with three fingers or four fingers</p> 	<p data-bbox="808 858 1052 886">Returns to the desktop</p>
<p data-bbox="167 1148 545 1176">Swipe left or right with three fingers</p> 	<p data-bbox="808 1148 1122 1176">Switches between open apps</p>

Table 13. Multi-finger touchpad gestures (continued)

Gesture	Function
Tap three fingers on the touchpad 	Opens Windows Search
Tap four fingers on the touchpad 	Opens Notification Center

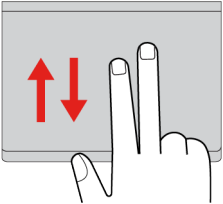
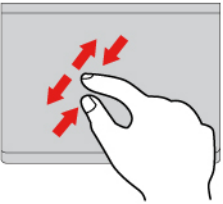

### Modify the default functions for touchpad gestures

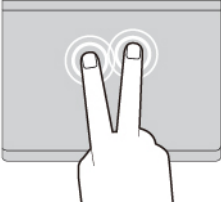
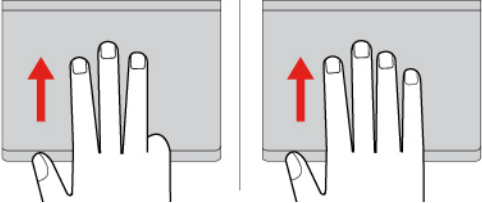
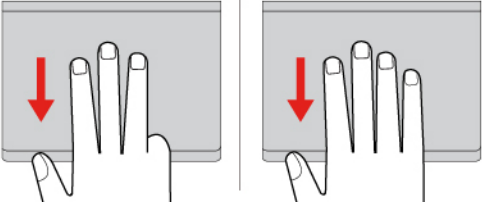
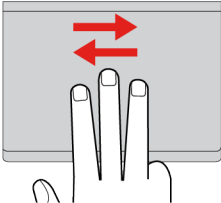
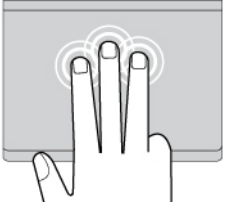
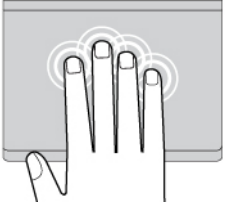
The functions for three-finger touchpad gestures can be modified in Windows Settings.

- Step 1. Select **Settings** → **Bluetooth & devices** → **Touchpad**.
- Step 2. Under **Three-finger gestures**, use the drop-down lists to modify the functions for the swipe or tap gestures.

### Touch operations supported by Windows

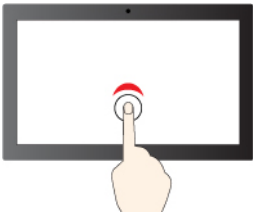
For computers with a touch-enabled screen, you can touch the screen directly with your fingers and interact with your computer in a more natural way. The following table lists frequently used touch operations that are supported by the Windows operating system.

Touch operation	Used for
 Tap	Opening apps, documents, and other functions on the taskbar or the Start menu
 Tap twice quickly	Opening apps that are pinned on the desktop

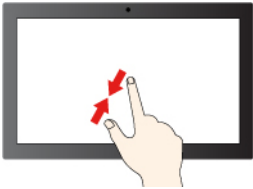
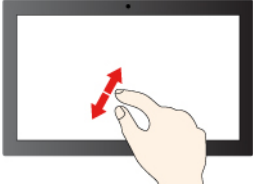
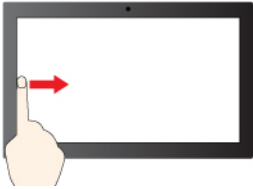
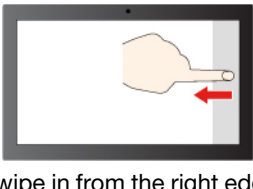
Touch operation	Used for
 Tap, hold and lift	Opening the context menu
 Pinch	Zooming out
 Spread	Zooming in
 Swipe in from the left edge	Opening the widgets panel
 Swipe in from the right edge	Opening the notification center

The Windows operating system also supports 3- and 4-finger gestures on the screen and the touchpad. You can set them up in **Settings → Bluetooth & devices**.

## Connect to an external display

### Connect to a wired display

Connect your computer to the desired display with an appropriate cable.

- Step 1. Connect one end of the display cable to the HDMI connector or a multi-purpose USB Type-C connector on your computer.
- Step 2. Connect the other end of the cable to the display.

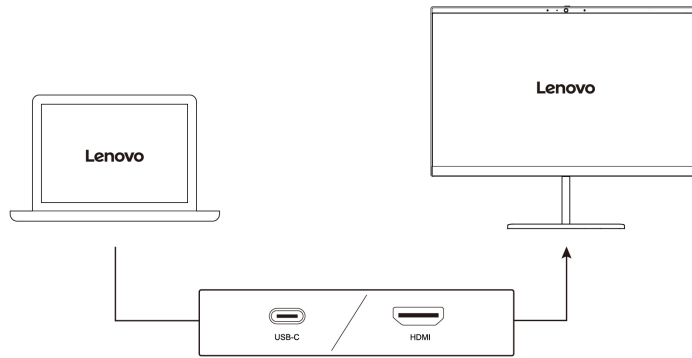

## Connect to a wireless display

Ensure that:

- Both your computer and the display support Miracast® technology.
- The display is connected to the same Wi-Fi network as your computer and is discoverable.

- Step 1. Press Windows key + K.  
The computer searches for wireless display devices and audio devices and lists the results.
- Step 2. Select the display you want to connect to, and then follow the on-screen instructions.

## Change display settings

- Step 1. Right-click on a blank area on the desktop, and then select **Display settings**.  
Your computer shows the **Display** window.
- Step 2. Select the display for which you want to change the settings.
- Step 3. Change the display settings as necessary.

## Set the display mode

- Step 1. Press or fn + .
- Your computer shows a list of display modes, with the current mode highlighted.
- Step 2. Select a display mode from the list.

## Turn on night light

The night light feature in Windows 11 enables users to switch to warmer color tones, reducing blue light emission to alleviate eye strain or fatigue.

- Step 1. Open the quick settings menu by selecting the network, sound, or battery icons ( ) on the far right of the taskbar or by using the keyboard shortcut **Win** + **A**.
- Step 2. Select the button for night light to turn it on or off.

**Note:** Some Windows 11 versions allow users to customize their quick settings. If the night light button is not visible, you can add it to the quick settings menu by selecting the edit button ().

For more tips on reducing eye strain or fatigue, visit <https://www.lenovo.com/us/en/compliance/visual-fatigue>.

## Adjust color temperature

If Windows 11 night light mode is turned on, you can adjust the color temperature of the screen.

- Step 1. Select **Start** → **Settings**.
- Step 2. Select **System** → **Display** → **Night light settings**.
- Step 3. Move the slider to adjust the color temperature.

**Note:** Selected Lenovo PCs are low blue-light certified. These PCs undergo testing with the night light turned on and the color temperature value set at 48 or above.

## Protect your privacy using the camera shutter

The camera shutter is a mechanical component that prevents any attempt from capturing your image, thus protecting your privacy. To cover the camera lens, slide the camera shutter to the left. When you want to use the camera, slide the camera shutter to the right.

If you slide the camera shutter to the left during a video call, people on the video call will not be able to see you. If you slide the camera shutter back to the right, they will be able to see you again.

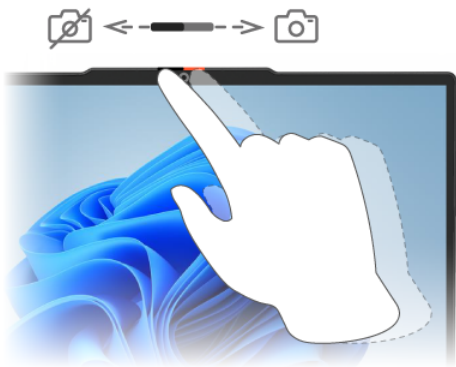

**Note:** Depending on your computer model, human presence detection and ambient light sensing functions may be unavailable when the camera lens is blocked.

---

## The Novo Button menu

The Novo Button menu can be displayed before the operating system starts. From the menu, you can choose to

- Open the BIOS/UEFI setup utility
- Open the boot device selection menu
- Open the Windows startup options screen

**Note:** From the Windows startup options screen, you can then choose to

- Start your computer using a recovery drive
- Reset your computer
- Open advanced options screen

## Open the Novo Button menu

For Lenovo computers with a Novo button, you can press the button to open the Novo Button menu.

- Step 1. Turn off the computer.
- Step 2. Open the LCD screen and press the Novo button.

**Note:** Alternatively, turn off the computer. Press fn and the power button to open the Novo Button menu.

---

## Set passwords in UEFI/BIOS setup utility

This section introduces the types of passwords that you can set in the UEFI (Unified Extensible Firmware Interface) or BIOS (Basic Input/Output System) setup utility.

### Password types

You can set various types of passwords in the UEFI/BIOS setup utility.

Password type	Pre-requisite	Usage
Administrator password	No	You must enter it to start the setup utility.
User password	The administrator password must be set.	You can use the user password to start the setup utility.
Master hard disk password	No	You must enter it to start the operating system.
User hard disk password	The master hard disk password must be set.	You can use the user hard disk password to start the operating system.

#### Notes:

- All passwords set in the setup utility consist of alphanumeric characters only.
- If you start the setup utility using the user password, you can only change a few settings.

### Set administrator password

You set the administrator password to prevent unauthorized access to the UEFI/BIOS setup utility.

**Attention:** If you forget the administrator password, a Lenovo authorized service personnel cannot reset your password. You must take your computer to a Lenovo authorized service personnel to have the system board replaced. Proof of purchase is required and a fee will be charged for parts and service.

- Step 1. Open the UEFI/BIOS setup utility.
- Step 2. Select **Security → Set Administrator Password** and press enter.
- Step 3. Enter a password string that contains only letters and numbers and then press enter.
- Step 4. Enter the password again and press enter.
- Step 5. Select **Exit → Exit Saving Changes**.

Next time you start the computer, you must enter the administrator password to open the setup utility. If **Power on Password** is enabled, you must enter the administrator password or the user password to start the computer.

### Change or remove administrator password

Only the administrator can change or remove the administrator password.

- Step 1. Open the UEFI/BIOS setup utility using the administrator password.
- Step 2. Select **Security → Set Administrator Password** and press enter.

- Step 3. Enter the current password.
- Step 4. In the **Enter New Password** text box, enter the new password.
- Step 5. In the **Confirm New Password** text box, enter the new password again.

**Note:** If you want to remove the password, press enter in both text boxes without entering any character.

- Step 6. Select **Exit → Exit Saving Changes**.

If you remove the administrator password, the user password is also removed.

## Set user password

You must set the administrator password before you can set the user password.

The administrator of the setup utility might need to set a user password for use by others.

- Step 1. Open the UEFI/BIOS setup utility using the administrator password.
- Step 2. Select **Security → Set User Password** and press enter.
- Step 3. Enter a password string that contains only letters and numbers and then press enter. The user password must be different from the administrator password.
- Step 4. Enter the password again and press enter.
- Step 5. Select **Exit → Exit Saving Changes**.

## Enable power-on password

If the administrator password has been set, you can enable power-on password to enforce greater security.

- Step 1. Open the UEFI/BIOS setup utility.
- Step 2. Select **Security → Power on Password** and press enter.  
**Note:** The administrator password must be set in advance.
- Step 3. Change the setting to **Enabled**.
- Step 4. Select **Exit → Exit Saving Changes**.

If power-on password is enabled, a prompt appears on the screen every time you turn on the computer. You must enter the administrator or user password to start the computer.

## Set hard disk password

You can set a hard disk password in the setup utility to prevent unauthorized access to your data.

**Attention:** Be extremely careful when setting a hard disk password. If you forget the hard disk password, a Lenovo authorized service personnel cannot reset your password or recover data from the hard disk. You must take your computer to a Lenovo authorized service personnel to have the hard disk drive replaced. Proof of purchase is required and a fee will be charged for parts and service.

- Step 1. Open the UEFI/BIOS setup utility.
- Step 2. Select **Security → Set Hard Disk Password** and press enter.  
**Note:** If you start the setup utility using the user password, you cannot set hard disk password.
- Step 3. Follow on-screen instructions to set both master and user passwords.

**Note:** The master and user hard disk passwords must be set at the same time.

Step 4. Select **Exit** → **Exit Saving Changes**.

If the hard disk password is set, you must provide the correct password to start the operating system.

## Change or remove hard disk password

Step 1. Open the UEFI/BIOS setup utility.

Step 2. Select **Security**.

Step 3. Change or remove the hard disk password.

To change or remove master password, select **Change Master Password** and press enter.

**Note:** If you remove the master hard disk password, the user hard disk password is also removed.

To change user password, select **Change User Password** and press enter.

**Note:** The user hard disk password cannot be removed separately.

Step 4. Select **Exit** → **Exit Saving Changes**.

---

## Change settings in UEFI/BIOS setup utility

This section introduces what is UEFI/BIOS and the operations you can perform in its setup utility.

### What is UEFI/BIOS setup utility

UEFI/BIOS is the first program that runs when a computer starts. UEFI/BIOS initializes hardware components and loads the operating system and other programs. Your computer may include a setup program (setup utility) with which you can change certain UEFI/BIOS settings.

### Open the UEFI/BIOS setup utility

Step 1. Turn on or restart the computer.

Step 2. When the Lenovo logo appears on the screen, press F2 repeatedly.

**Note:** For computers with hotkey mode enabled, press fn + F2.

### Select boot devices

Normally, the computer starts to a boot manager loaded from the secondary storage device of the computer. Occasionally, you may need to start the computer to a program or boot manager loaded from another device or a network location. After the system firmware initializes all devices, you can press an interruption key to display the boot menu and select a desired boot device.

Step 1. Turn on or restart the computer.

Step 2. Press F12.

Step 3. From the boot device menu, select a boot device to start the computer.

You can make a permanent change on boot devices in the UEFI/BIOS setup utility. Select the **Boot** menu; in the **EFI** section, select the desired boot device and move it to the top of the device list. Save changes and exit the setup utility for the change to take effect.

## Change hotkey mode

- Step 1. Open the UEFI/BIOS setup utility.
- Step 2. Select **Configuration** → **Hotkey Mode** and press enter.
- Step 3. Change the setting to **Disabled** or **Enabled**.
- Step 4. Select **Exit** → **Exit Saving Changes**.

## Enable or disable always-on

For some Lenovo computers with always-on connectors, the always-on function can be enabled or disabled in the UEFI/BIOS setup utility.

- Step 1. Open the UEFI/BIOS setup utility.
- Step 2. Select **Configuration** → **Always On USB** and press enter.
- Step 3. Change the setting to **Disabled** or **Enabled**.
- Step 4. Select **Exit** → **Exit Saving Changes**.

## Enable or disable Flip to Start

When Flip to Start is enabled, you can turn on the computer by flipping open the screen.

- Step 1. Open the UEFI/BIOS setup utility.
- Step 2. Select **Configuration**.
- Step 3. Change the setting for **Flip to Start**.

**Note:** You may also set Flip to Start in Lenovo Vantage or Lenovo PC Manager.

---

## Chapter 4. Accessories

---

### Lenovo Yoga Pen

Depending on the model, your PC may come with a Lenovo Yoga Pen (hereinafter referred to as “the pen” in this section). The pen offers a more precise and effortless way to write and sketch. When not in use, the pen can be magnetically attached to the upper cover of your PC.

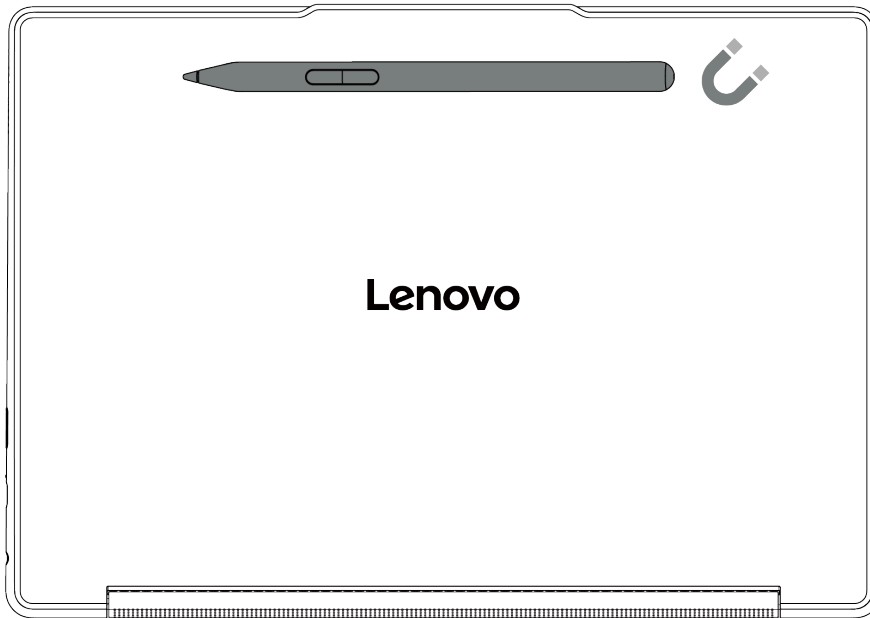

Refer to the illustration and the table for detailed information on the functions of the pen.

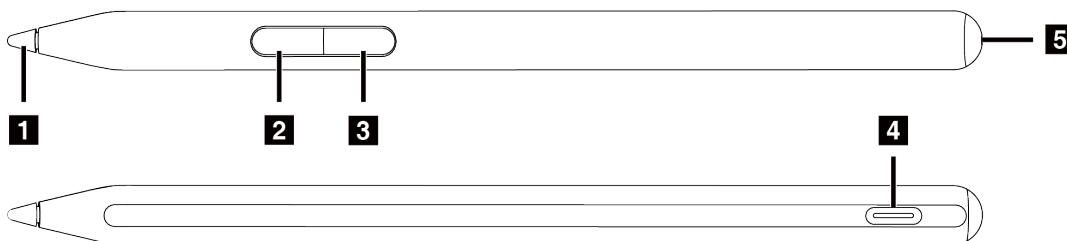

Item	Description
1. Pen tip	Write or draw on the touch screen. <b>Note:</b> Apply an appropriate amount of pressure when writing or sketching on the screen.
2. Lower button*	To erase text or drawings, hold the button to erase the object in supported apps.
3. Upper button*	To right-click, hold the button and tap the screen in supported apps.
4. USB Type-C connector**	Charge the pen using a USB Type-C cable.
5. Power status LED	<ul style="list-style-type: none"> <li>• Blinking amber: The battery level is low.</li> <li>• Solid amber: The pen is charging.</li> <li>• Solid white: The pen has been fully charged.</li> </ul>

\* The default function of each button may vary in different apps.

\*\* The pen battery is set to shipping mode at the factory to prevent over-discharge during transit. Connect the pen to a power source to deactivate its shipping mode before using it for the first time.

## Pen settings

You can view the pen status and configure pen settings in the Lenovo Pen Settings app.

To open this app, type **Lenovo Pen Settings** in the Windows search box, and then select the matched result.

From Lenovo Pen Settings, you can configure the following settings:

- View the battery status of the pen
- Change the functions of the pen buttons
- Enable or disable hovering click
- Set one pen button as the radial menu for quick access

### Notes:

- If Lenovo Pen Settings is not installed on your PC, download and install the latest WinTab driver from <https://support.lenovo.com> or from Microsoft Store.
- Additionally, you can configure pen settings under Pen & Windows Ink in Windows Settings.

---

## Lenovo TWS YOGA PC Edition

If you purchased the Lenovo TWS YOGA PC Edition earbuds when placing your order, the earbuds can integrate with your Yoga PC to provide an effortless audio experience.

After establishing a Bluetooth connection between the earbuds and your PC, you can view the status of your earbuds and customize the settings in Lenovo Vantage or Lenovo PC Manager.

To purchase the Lenovo TWS YOGA PC Edition earbuds separately, go to <https://www.lenovo.com/accessories>.

---

## Chapter 5. Help and support

---

### Frequently asked questions

#### Where can I get the latest device drivers and UEFI/BIOS

- Lenovo Vantage or Lenovo PC Manager
- Lenovo Support Web site at <https://support.lenovo.com>.
- Windows Update

#### What should I do if my computer stops responding

Press and hold the power button until the computer turns off. Then restart the computer.

#### What should I do if I spill liquid on the computer

1. Carefully unplug the ac power adapter and turn off the computer immediately. The more quickly you stop the current from passing through the computer the more likely you will reduce damage from short circuits.

**Attention:** Although you might lose some data or work by turning off the computer immediately, leaving the computer on might make your computer unusable.

2. Wait until you are certain that all the liquid is dry before turning on your computer.

**CAUTION:**

**Do not try to drain out the liquid by turning over the computer. If your computer has keyboard drainage holes on the bottom, the liquid will be drained out through the holes.**

#### Why does my computer start automatically when I open the lid

Your computer may have Flip to Start enabled. Many Lenovo notebook computers include a sensor that can detect the angle at which the lid is opened. When you open the lid, the sensor can detect this behavior. If Flip to Start is enabled, the computer will respond by starting up automatically.

If you don't like this feature, you can disable it. Flip to Start can be enabled or disabled in the setup utility program for the PC's firmware or the Lenovo Vantage app.

#### Why does my screen brightness change constantly

Your computer may include an ambient light sensor and the adaptive brightness feature is enabled. The light sensor can detect the intensity of the surrounding light. Using data provided by the sensor, the operating system can dynamically adjust the screen brightness.

The adaptive brightness feature of the operating system can be disabled. For Windows operating systems, adaptive brightness settings are usually found in **Settings** → **System** → **Display**.

#### What should I do if I cannot connect to the network

1. Right-click on the network icon  on the right side of the task bar.
2. Select **Diagnose network problems** and then follow the on-screen instructions.

## What should I do with blue screen errors

Blue screen errors can occur if a serious problem causes Windows to shut down or restart unexpectedly. To fix the errors, you can take the following steps to use the Blue Screen Troubleshooter in the Get Help app:

- Step 1. Type **Get Help** in the Windows search box and then press Enter.
- Step 2. In the search box of the Get Help app, type **Troubleshoot BSOD error** and then press Enter.
- Step 3. Follow the guided walkthrough.

## What should I do if the screen flickers

Screen flickering in Windows is usually caused by a display driver issue or incompatible app. You can first determine whether the problem is caused by a display driver issue or an incompatible app by checking if Task Manager flickers. To open Task Manager, press Ctrl+Alt+Delete or Ctrl+Shift+Esc.

1. If Task Manager also flickers, the display driver is probably causing the problem. In this scenario, roll back your display driver:
  - a. Type **device manager** in the Windows search box and then press Enter.
  - b. Under **Display adapters**, select a display adapter.
  - c. Select the **Driver** tab and then select **Roll Back Driver**.
  - d. Click **Yes** to roll back your display driver and restart your computer.

**Note:** If the **Roll Back Driver** option is unavailable, Windows does not have a previous driver to roll back to. In this scenario, you can try updating or uninstalling your display driver in the **Driver** tab.

2. If Task Manager does not flicker, an incompatible app is probably causing the problem. In this scenario, update or uninstall an incompatible app:
  - a. Check if any app needs to be updated from the Microsoft Store or the manufacturer's site. If yes, update the app.
  - b. If step a does not work, uninstall the app:
    - 1) Select the Start menu on the taskbar and then select **Settings**.
    - 2) Select **Apps → Installed apps**.
    - 3) Scroll down the list, find the app you want to uninstall, and then select **Uninstall**.
    - 4) In the popup window, select **Uninstall**.
    - 5) If you're asked to confirm your choice, select **Yes**.

**Note:** Check in the recently used app if screen flickering usually occurs in a specific app. If yes, prioritize uninstalling that app.

After uninstalling an app, restart your computer and check if the screen flickering issue is resolved. If the issue retains, uninstall each app one by one until the issue is resolved.

## What should I do if my touchpad does not respond

If your touchpad does not respond, it might be because you have disabled the touchpad or your touchpad driver is out-of-date or malfunctioning. To solve the problem, you can try the following solutions.

- Enable the touchpad:
  1. Go to **Start → Settings → Bluetooth & devices → Touchpad**.
  2. Turn on the **Touchpad** toggle.

**Note:** Alternatively, you can also press the key combination fn + M to enable or disable the touchpad.

- Update the touchpad driver:

1. Type **Device Manager** in the Windows search box and then press Enter.
  2. Click the arrow icon > next to **Human Interface Devices** to expand the section.
  3. Right-click the touchpad, select **Update driver**, and follow the on-screen instructions.
- If a touchpad problem occurs after a recent driver update, follow the instructions below to roll back to the previously installed driver:
    1. Type **Device Manager** in the Windows search box and then press Enter.
    2. Click the arrow icon > next to **Human Interface Devices** to expand the section.
    3. Right-click the touchpad, and select **Properties**.
    4. Under **Driver**, select **Roll Back Driver** and follow the on-screen instructions.

## What should I do if the audio does not work

If you encounter any audio problems, such as no audio or malfunctioning audio, try the following solutions to troubleshoot and fix the issue:

1. Verify your audio settings:
  - a. Go to **Start → Settings → System → Sound**.
  - b. Verify that the sound output and input devices are selected correctly.
 

**Note:** If you are using an external audio device, ensure that the device is properly connected to your computer.
  - c. Verify that the volume is properly set and your computer is not muted.
2. Run the audio troubleshooter:
  - a. Go to **Start → Settings → System → Sound**.
  - b. Under **Advanced**, find **Troubleshoot common sound problems**, and click **Output devices** or **Input devices** to troubleshoot and fix the problem.

For more solutions to audio problems, go to <https://support.lenovo.com/solutions/ht501860>.

## What should I do if my camera can't be launched or found

If your camera can't be launched or found, try the following solutions one by one to troubleshoot and fix the issue:

1. Ensure that your camera is not disconnected or covered:
  - If you are using an external camera, ensure that you have connected it to a working USB connector on your computer.
  - If you are using an integrated camera, slide the camera shutter or camera switch to the on position.
2. If you are using an integrated camera, it might be disabled. To enable your camera:
  - a. Open the **Start** menu, and click **Settings → Bluetooth & devices → Camera**.
  - b. Check if the camera is connected or disabled. If it is disabled, enable the camera.
3. The apps you are using might not have access to your camera. To authorize access to your camera:
  - a. Open the **Start** menu, and select **Settings → Privacy & security → Camera**.
  - b. Turn on **Camera access** switch and **Let apps access your camera** switch.
4. Your antivirus software settings might block access to your camera. Go to your antivirus software settings and unblock the access.
5. Your camera driver might be uninstalled or out-of-date. To update the camera driver:
  - a. Type **device manager** in the Windows search box and then press Enter.

- b. Click **Device Manager** from the list of results. The Device Manager window opens.
  - c. Click arrow icon > next to **Camera** to expand the section.
  - d. Right-click the camera that you would like to update.
  - e. Select **Update driver** and follow the on-screen instructions.
6. If your camera still does not work, run the automated camera troubleshooter in the Get Help app. To open the Get help app:
    - a. Open the **Start** menu, and click **Settings → Privacy & security → Camera**.
    - b. Scroll down to the bottom. Click **Get help** and follow the on-screen instructions.

## What should I do if my keyboard does not work

If your keyboard does not work or types wrong characters, try the following solutions to troubleshoot and fix the issue:

1. Ensure that the keyboard is well connected.
  - If you are using a wired keyboard, check if it is connected to your computer correctly or try to connect the keyboard to another compatible connector on your computer.
  - If you are using a wireless keyboard, ensure that your keyboard is powered on. Check if the dongle is connected to your computer correctly or the Bluetooth connection with your computer is established.
2. Ensure that the keyboard layout settings are correct. Take the following steps:
  - a. Go to **Settings → Time & language → Language & region**.
  - b. Under **Preferred languages**, click on the three horizontal dots next to your primary language preference and select **Language options**.
  - c. Under **Installed keyboards**, check the keyboard layout and add the corresponding keyboard if you're not using the right one.
3. Ensure that the keyboard is in good status. Take the following steps:
  - a. Type **device manager** in the Windows search box and then press Enter.
  - b. Click **Device Manager** from the list of results. The Device Manager window opens.
  - c. Click arrow icon > next to **Keyboard** to expand the section.
  - d. Double-click the keyboard that is not working and check the status.
  - e. If it is not working properly, select **Driver** from the tabs on the top and click **Uninstall device** to uninstall the device.
  - f. Apply Windows Update to install the latest driver automatically.
4. Ensure that the sticky keys and filter keys are disabled. Take the following steps:
  - a. Open the **Start** menu, and click **Settings → Accessibility → Keyboard**.
  - b. Disable **Sticky keys** switch and **Filter keys** switch.
5. Restart your computer.

## What should I do if my keyboard backlight does not work

If your keyboard backlight does not work, try the following solutions to troubleshoot and fix the issue:

1. Adjust the keyboard backlight by pressing the key combination fn + Space.
2. Open the firmware setup utility and press the key combination fn + Space to check if the keyboard backlight works. If the backlight works in the firmware setup utility, update the UEFI/BIOS to the latest version.
3. Update the keyboard driver:

- a. Type **Device Manager** in the Windows search box and then press Enter.
- b. Click the arrow icon next to **Keyboards** to expand the section.
- c. Right-click the keyboard you would like to update.
- d. Select **Update driver** and follow the on-screen instructions.

## How to reset my Windows password

If you forget your Windows password and want to reset one, you can take the following actions.

- Do the following if you have set security questions.
  1. Click **Reset password** on the sign-in screen after you have entered an incorrect password.
 

**Note:** Contact your administrator if you do not see an option to reset your password.
  2. Follow on-screen instructions to reset a new password.
- Do the following if you have created a password reset disk.
  1. Connect a password reset disk to a USB-compatible connector on your computer.
  2. Follow on-screen instructions to reset your password.
- Do the following if you have an administrator account.
  1. Sign in to your computer with the local administrator account.
  2. Follow on-screen instructions to reset your password.

## What should I do if the built-in battery cannot be charged

1. Ensure that you use the correct power adapter with the proper wattage. Low-wattage power adapters might cause battery charging problem.
2. Exit the heavy-loading programs and charge the computer again. To check the loads of programs in process, press **ctrl + alt + delete** and then select **Task Manager → Processes**.
3. Move your computer to a cool and well-ventilated spot. Battery charging may also be affected by its temperature.
4. Update the battery driver or UEFI/BIOS to the latest version. To proceed with a driver update or a BIOS update, select **System Update** in the Lenovo Vantage app. It will automatically check for any updates you may need.

---

## Self-help resources

Use the following self-help resources to learn more about the computer and troubleshoot problems.

Resources	How to access?
Troubleshooting and frequently asked questions	<ul style="list-style-type: none"> <li>• <a href="https://www.lenovo.com/tips">https://www.lenovo.com/tips</a></li> <li>• <a href="https://forums.lenovo.com">https://forums.lenovo.com</a></li> </ul>
Accessibility information	<a href="https://www.lenovo.com/accessibility">https://www.lenovo.com/accessibility</a>

Resources	How to access?
Reset or restore Windows	<ul style="list-style-type: none"> <li>• Use Lenovo recovery options.               <ol style="list-style-type: none"> <li>1. Go to <a href="https://support.lenovo.com/HowToCreateLenovoRecovery">https://support.lenovo.com/HowToCreateLenovoRecovery</a>.</li> <li>2. Follow the on-screen instructions.</li> </ol> </li> <li>• Use Windows recovery options.               <ol style="list-style-type: none"> <li>1. Go to <a href="https://pcsupport.lenovo.com">https://pcsupport.lenovo.com</a>.</li> <li>2. Detect your computer or manually select your computer model.</li> <li>3. Click <b>Diagnostics</b> → <b>Operating System Diagnostics</b> and then follow the on-screen instructions.</li> </ol> </li> </ul>
Use Lenovo Vantage or Lenovo PC Manager to:	
<ul style="list-style-type: none"> <li>• Download and install the latest drivers and firmware.</li> <li>• Configure hardware settings</li> <li>• Diagnose computer hardware problems.</li> <li>• Check the computer warranty status.</li> </ul>	Use Windows Search.
Product documentation:	
<ul style="list-style-type: none"> <li>• <a href="#">Generic Safety and Compliance Notices</a></li> <li>• <i>Safety and Warranty Guide</i></li> <li>• <i>Setup Guide</i></li> <li>• This <i>User Guide</i></li> <li>• <i>Regulatory Notice</i></li> </ul>	<ol style="list-style-type: none"> <li>1. Go to <a href="https://support.lenovo.com">https://support.lenovo.com</a>.</li> <li>2. Detect your computer or select computer model manually.</li> <li>3. Select <b>Documentation</b> and filter out the documentation you want.</li> </ol>
Lenovo Support Web site with the latest support information of the following:	
<ul style="list-style-type: none"> <li>• Drivers and software</li> <li>• Diagnostic solutions</li> <li>• Product and service warranty</li> <li>• Product and parts details</li> <li>• Knowledge base and frequently asked questions</li> </ul>	Visit <a href="https://support.lenovo.com">https://support.lenovo.com</a>
Windows help information	<ul style="list-style-type: none"> <li>• Use <b>Get Help</b> or <b>Tips</b>.</li> <li>• Use Windows Search.</li> <li>• Microsoft support Web site: <a href="https://support.microsoft.com">https://support.microsoft.com</a></li> </ul>

## What is a CRU?

Customer replaceable units (CRUs) are parts that can be upgraded or replaced by the customer. A Lenovo computer may contain the following types of CRUs:

Self-service CRU

Parts that can be installed or replaced easily by customer themselves or by trained service technicians at an additional cost.

Optional-service CRU

Parts that can be installed or replaced by customers with a greater skill level. Trained service technicians can also provide service to install or replace the parts under the type of warranty designated for the customer's machine.

If you intend to install a CRU, Lenovo will ship the CRU to you. You might be required to return the defective part that is replaced by the CRU. When return is required: (1) return instructions, a prepaid shipping label, and a container will be included with the replacement CRU; and (2) you might be charged for the replacement CRU if Lenovo does not receive the defective CRU within thirty (30) days of your receipt of the replacement CRU. For full details, see the *Lenovo Limited Warranty* at [https://www.lenovo.com/warranty/llw\\_02](https://www.lenovo.com/warranty/llw_02).

---

## CRUs for your product model

The table below lists the CRUs and CRU types that are defined for your product model.

Part	Self-service CRU	Optional-service CRU
Power cord	X	
ac power adapter	X	
Lenovo Yoga Pen*	X	

\* for selected models

### Notes:

- CRU replacement instruction is provided in one or more of the following publications and are available from Lenovo at any time upon your request.
  - the product *User Guide*
  - the printed publications that came with the product
- Replacement of any parts not listed above, including the built-in rechargeable battery, should be done by a qualified repair technician or by ensuring that you carefully follow all instructions provided by Lenovo. You can also find Lenovo-authorized repair facilities by going to <https://support.lenovo.com/partnerlocator> for more information.

---

## Call Lenovo

If you have tried to correct the problem yourself and still need help, you can call Lenovo Customer Support Center.

## Before you contact Lenovo

Record product information and problem details before you contact Lenovo.

Product information	Problem symptoms and details
<ul style="list-style-type: none"> <li>• Product name</li> <li>• Machine type and serial number</li> </ul>	<ul style="list-style-type: none"> <li>• What is the problem? Is it continuous or intermittent?</li> <li>• Any error message or error code?</li> <li>• What operating system are you using? Which version?</li> <li>• Which software applications were running at the time of the problem?</li> <li>• Can the problem be reproduced? If so, how?</li> </ul>

**Note:** The product name and serial number can usually be found on the bottom of the computer, either printed on a label or etched on the cover.

## Lenovo Customer Support Center

During the warranty period, you can call Lenovo Customer Support Center for help.

### Telephone numbers

For a list of the Lenovo Support phone numbers for your country or region, go to <https://pcsupport.lenovo.com/supportphonenumberlist>.

**Note:** Phone numbers are subject to change without notice. If the number for your country or region is not provided, contact your Lenovo reseller or Lenovo marketing representative.

### Services available during the warranty period

- Problem determination - Trained personnel are available to assist you with determining if you have a hardware problem and deciding what action is necessary to fix the problem.
- Lenovo hardware repair - If the problem is determined to be caused by Lenovo hardware under warranty, trained service personnel are available to provide the applicable level of service.
- Engineering change management - Occasionally, there might be changes that are required after a product has been sold. Lenovo or your reseller, if authorized by Lenovo, will make selected Engineering Changes (ECs) that apply to your hardware available.

### Services not covered

- Replacement or use of parts not manufactured for or by Lenovo or nonwarranted parts
- Identification of software problem sources
- Configuration of UEFI/BIOS as part of an installation or upgrade
- Changes, modifications, or upgrades to device drivers
- Installation and maintenance of network operating systems (NOS)
- Installation and maintenance of programs

For the terms and conditions of the Lenovo Limited Warranty that apply to your Lenovo hardware product, see “Warranty information” in the *Safety and Warranty Guide* that comes with your computer.

## Purchase additional services

During and after the warranty period, you can purchase additional services from Lenovo at <https://pcsupport.lenovo.com/warrantyupgrade>.

Service availability and service name might vary by country or region.

---

## Chapter 6. PC and accessibility

PCs are powerful general-purpose computing devices that many individuals rely on for accessing information, connecting with friends, pursuing education, conducting research, and completing work tasks. This reliance extends to individuals with vision, hearing, cognitive, or mobility impairments, as well as to those whose abilities may decline due to illness or aging.

This chapter explores the accessibility features available on your Lenovo PC, including both hardware components and those offered by the pre-installed operating system. By gaining a comprehensive understanding of the available accessibility features and how to activate and configure them, you can enhance your PC's usability for individuals with disabilities.

---

### Accessibility features of the PC hardware

Lenovo PCs are designed with accessibility in mind. Throughout the design process, special considerations are prioritized for individuals with disabilities and best industry practices are implemented in hardware design.

#### USB connectors for connecting assistive technology devices

Several types of assistive technology devices are available on the market that can be connected to a PC to enhance its accessibility. For example, a refreshable braille display is an assistive technology device that enables individuals who are both deaf and blind to use a PC. When connected to a PC, a refreshable braille display can work in conjunction with a compatible screen reader to provide tactile output in braille characters. Blind individuals who have been trained to read braille can run their fingers over the display to comprehend the information presented on the PC.

Many assistive technology devices utilize USB technology for connectivity. Most Lenovo PCs are equipped with at least one USB connector that adheres to the relevant USB specifications and is backward compatible. A Lenovo PC may feature a USB Standard-A connector, a USB Type-C connector, or both. If the plug type of the assistive technology device does not match the USB connector on your PC, you can easily purchase and use a USB adapter to resolve the issue.

#### Keyboard accessibility

The keyboard serves as the primary input device for many PC users. Lenovo keyboards, whether integrated or supplied separately with the PC, are designed and manufactured with accessibility in mind. This section highlights the accessibility features of Lenovo keyboards that benefit all users, including those with disabilities.

##### keyboard layout

The alphabetic keys on a Lenovo keyboard are arranged in a QWERTY layout, which is standard for input devices featuring alphabetic keys. The F and J keys have bumps that make them tactilely distinguishable from other keys. This feature serves as an orientation aid for skilled typists, allowing them to rest their index fingers without looking at the keys. Some Lenovo keyboards include a separate numeric keypad. The numeric keys are organized in four rows and three columns, arranging in ascending order from left to right and bottom to top. Additionally, the 5 key features a bump to make it tactilely distinguishable.

##### Standard modifier keys

Lenovo keyboards are equipped with standard modifier keys for PCs, including:

- the alt key

the ctrl key  
the shift key  
the Windows logo key

These keys are extensively used as the modifier key for shortcuts by the operating system and other applications.

### **The tab key**

The tab key is located in the leftmost column of the keyboard. For operating systems, applications, and web documents that are designed with accessibility in mind, users can press the tab key and alt + tab (in reverse order) to cycle through the interactive elements.

### **Hotkeys**

Many Lenovo keyboards feature hotkeys in the top row, offering convenient access to frequently used settings.

### **The fn key and the fnlock**

The fn key is a Lenovo-defined modifier key. It can be used with the top-row dual-function keys to switch their functionalities. It can also be used with several other keys to access Lenovo defined settings.

The fnlock is a switch that can be turned on and off by pressing fn + esc. Instead of holding down the fn key to switch the functionality of dual-functionkeys, you can turn on fnlock. This feature allows users to access both hotkey and function key functionalities without the need to press two keys simultaneously.

### **Keyboard backlight**

Many Lenovo keyboards are equipped with backlights to help you use the keyboard in dark lighting conditions. The backlights can be controlled by pressing fn + Space.

## **Biometric devices**

Some Lenovo PCs are equipped with biometric devices that facilitate easy and secure identity authentication. If your PC includes an IR LED and an IR camera, you can enable facial recognition in Windows 11. Additionally, you can use your fingerprint for authentication on PCs with a fingerprint reader. Biometric identity authentication can be particularly beneficial for users who find it difficult typing passwords.

**Note:** When biometric devices are used for device authentication, they are not the only available method for this purpose. If biometric authentication fails, you can use a password or PIN to sign in to Windows.

---

## **Accessibility features of Windows 11**

An operating system is a crucial piece of software installed on a PC. It plays a vital role in the PC's basic functionality by providing a user interface, various tools for system management, and a foundation upon which additional specialized applications can be installed.

Microsoft's Windows 11 is a modern operating system that comes preinstalled on many Lenovo PCs. It offers a rich set of accessibility features designed for individuals with diverse disabilities. This section outlines the accessibility features available in Windows 11, explains how to activate them, and discusses the benefits they provide.

**Notes:** The following accessibility features of Windows have been tested and confirmed to deliver their essential functionalities on Lenovo PCs that come pre-installed with Windows 11.

- Narrator

- Magnifier

## Configuring accessibility features in the Settings app

Windows 11 provides a centralized location within the Settings app for activating and configuring all accessibility features. You can access this section by selecting **Start → Settings → Accessibility**. Additionally, the keyboard shortcut Windows logo key + U provides quick access to this interface.

### Narrator

Narrator is Windows 11's built-in screen-reading application. It can read screen content aloud to users and also accept input from the keyboard, enabling individuals with visual impairments to navigate effectively within Windows 11, use applications, and browse the web.

#### Start and stop Narrator

You can start and stop Narrator by selecting the toggle button for Narrator in the centralized Accessibility section of the Settings app. Additionally, the keyboard shortcut Windows logo key + ctrl + enter provides quick access to both the start and stop functions.

#### Customize Narrator

Narrator offers a variety of controls that allow you to customize it to suit your preferences. For example, you can install additional text-to-speech voices and select your preferred voice for Narrator. You also have the option to adjust the verbosity level to choose the type of content to be read. All Narrator settings are conveniently located in the centralized Accessibility section of the Settings app. Additionally, the keyboard shortcut Windows logo key + ctrl + N offers quick access to these settings.

## Adjusting text sizes, applying a high-contrast theme, and using Magnifier

For individuals who find it difficult to see text clearly on the screen, Windows offers the options of adjusting text sizes, applying a high-contrast theme, and using Magnifier.

### Adjust text sizes

If you find the text on the screen is too small to read, you can scale up the size of text displayed by Windows and other applications.

Step 1. Select **Start → Settings → Accessibility → Text size**.

Step 2. Use the slider and the preview pane to select a size that fits your need and then select **Apply**.

### Apply a high-contrast theme

For individuals with low vision, Windows 11 offers contrast themes that enhance text readability by using a background color that sharply contrasts with the text.

Step 1. Select **Start → Settings → Accessibility → Contrast themes**.

Step 2. In the dropdown list for **Contrast themes**, select one option and then select **Apply**.

To exit a contrast theme, select **None** from the dropdown list. The keyboard shortcut for turning on and off contrast theme is left alt + left shift + prt sc.

### Enable Magnifier

You can enable Windows 11 Magnifier to enlarge specific areas or the entire screen, making text and images easier to see.

Step 1. Select **Start → Settings → Accessibility → Magnifier**.

Step 2. Select the toggle to enable or disable Magnifier.

The keyboard shortcuts for enabling and disabling Magnifier are Windows logo key + Plus sign (+) and Windows logo key + esc, respectively. When Magnifier is enabled, you can use Windows logo key + plus sign (+) and minus sign (-) to zoom in and zoom out.

## Sticky Keys

Microsoft Windows offers numerous keyboard shortcuts that require users to hold down a modifier key (such as shift, ctrl, alt, or the Windows logo key) before pressing one or more additional keys. While these shortcuts provide significant convenience for many users, they can pose accessibility challenges for individuals who have difficulty holding down multiple keys at the same time.

Sticky Keys is an accessibility feature in Windows that, when enabled, allows users to press keys in sequence to activate shortcut functions. For example, instead of holding down the ctrl key and the C key simultaneously, users can press each key individually to copy text to the clipboard.

To enable Sticky Keys, press the shift key five times in quick succession. When the confirmation dialog box appears, select **Yes** to disable Sticky Keys, press the shift key five times again and choose **No** when prompted.

---

## Accessible user documentation

Documentation containing instructions for the use of the product, including its accessibility features, is available in accessible formats (such as HTML and PDF) on the Lenovo Support Website. When creating documentation, a series of industry standards and best practices are followed to ensure that the content is useful to as broad an audience as possible. Additionally, automated testing tools are employed to identify issues that may hinder the accessibility of information. These issues are addressed to the extent permitted by commonly available technologies.

## Accessibility features of user documentation

By adhering to industry standards and best practices, Lenovo documentation offers numerous features that facilitate the perception and understanding of the content. Additionally, several of these features are specifically designed to ensure that users of assistive technology devices can access information comparable to that available to those who do not rely on such devices.

### Perceivable content

Text content is presented using popular and easy-to-read fonts. Text colors are in high contrast with the background. Non-text elements, such as graphics and videos that convey important information, are accompanied by alternative text descriptions. Users with visual impairments can utilize screen readers to access information comparable to that available to sighted users.

### Understandable content

The documentation is presented visually in a well-structured and simple layout. It also includes hidden tags or other markup information that store the content's structure, which can be utilized programmatically by assistive technologies to convey this structure to users.

### Operable content

Documentation includes industry-standard tags for sectioning and interactive elements, such as titles, headings, various structural components, links, buttons, and input fields. Screen reader users can utilize standard modifier keys on the keyboard to effectively navigate and interact with the documentation.

## Testing documentation accessibility

Before being officially released, Lenovo documentation undergoes testing with automated tools to evaluate its accessibility. HTML documents are assessed for compliance with the success criteria outlined in the *Web Content Accessibility Guidelines (WCAG)*, a widely accepted set of standards designed to enhance web document accessibility. PDF documents are evaluated for accessibility using the accessibility checker in Adobe Acrobat for the same purpose. Automated testing tools help identify elements within a document that may present challenges when rendered by screen readers and other assistive technology devices. Accessibility issues identified by these automated tools are subsequently analyzed manually and corrected as needed.

---

## Appendix A. Important notice for Quebec consumers

In regard to section 79.18 of Quebec's Regulation respecting the application of the Consumer Protection Act, Lenovo in no way guarantees the availability of (a) replacement parts; (b) repair services; and (c) information necessary to maintain or repair the goods. For up-to-date information on the technical support and parts available for your purchase, please consult <https://support.lenovo.com/ca/en>

En ce qui concerne l'article 79.18 du Règlement d'application de la Loi sur la protection du consommateur du Québec, Lenovo ne garantit en aucune façon la disponibilité des éléments suivants : (a) les pièces de rechange; (b) les services de réparation; et (c) les renseignements nécessaires à l'entretien à la réparation du bien. Pour obtenir des renseignements à jour sur le soutien technique et les pièces disponibles pour votre achat, veuillez consulter <https://support.lenovo.com/ca/fr>.

---

## Appendix B. Notices and trademarks

### Notices

Lenovo may not offer the products, services, or features discussed in this document in all countries. Consult your local Lenovo representative for information on the products and services currently available in your area. Any reference to a Lenovo product, program, or service is not intended to state or imply that only that Lenovo product, program, or service may be used. Any functionally equivalent product, program, or service that does not infringe any Lenovo intellectual property right may be used instead. However, it is the user's responsibility to evaluate and verify the operation of any other product, program, or service.

Lenovo may have patents or pending patent programs covering subject matter described in this document. The furnishing of this document does not give you any license to these patents. You can send license inquiries, in writing, to:

Lenovo (United States), Inc.  
8001 Development Drive  
Morrisville, NC 27560  
U.S.A.

Attention: Lenovo Director of Licensing

LENOVO PROVIDES THIS PUBLICATION "AS IS" WITHOUT WARRANTY OF ANY KIND, EITHER EXPRESS OR IMPLIED, INCLUDING, BUT NOT LIMITED TO, THE IMPLIED WARRANTIES OF NON-INFRINGEMENT, MERCHANTABILITY OR FITNESS FOR A PARTICULAR PURPOSE. Some jurisdictions do not allow disclaimer of express or implied warranties in certain transactions, therefore, this statement may not apply to you.

Changes are made periodically to the information herein; these changes will be incorporated in new editions of the publication. To provide better service, Lenovo reserves the right to improve and/or modify the products and software programs described in the manuals included with your computer, and the content of the manual, at any time without additional notice.

The software interface and function and hardware configuration described in the manuals included with your computer might not match exactly the actual configuration of the computer that you purchase. For the configuration of the product, refer to the related contract (if any) or product packing list, or consult the distributor for the product sales. Lenovo may use or distribute any of the information you supply in any way it believes appropriate without incurring any obligation to you.

The products described in this document are not intended for use in implantation or other life support applications where malfunction may result in injury or death to persons. The information contained in this document does not affect or change Lenovo product specifications or warranties. Nothing in this document shall operate as an express or implied license or indemnity under the intellectual property rights of Lenovo or third parties. All information contained in this document was obtained in specific environments and is presented as an illustration. The result obtained in other operating environments may vary.

Lenovo may use or distribute any of the information you supply in any way it believes appropriate without incurring any obligation to you.

Any references in this publication to non-Lenovo Web sites are provided for convenience only and do not in any manner serve as an endorsement of those Web sites. The materials at those Web sites are not part of the materials for this Lenovo product, and use of those Web sites is at your own risk.

Any performance data contained herein was determined in a controlled environment. Therefore, the result obtained in other operating environments may vary significantly. Some measurements may have been made on development-level systems and there is no guarantee that these measurements will be the same on generally available systems. Furthermore, some measurements may have been estimated through extrapolation. Actual results may vary. Users of this document should verify the applicable data for their specific environment.

This document is copyrighted by Lenovo and is not covered by any open source license, including any Linux agreement(s) which may accompany software included with this product. Lenovo may update this document at any time without notice.

For the latest information or any questions or comments, contact or visit the Lenovo Web site:

<https://support.lenovo.com>

### **Trademarks**

Lenovo, the Lenovo logo and Yoga are trademarks of Lenovo. Thunderbolt is a trademark of Intel Corporation or its subsidiaries. Microsoft, Windows, and Windows Hello are trademarks of the Microsoft group of companies. DisplayPort is a trademark of the Video Electronics Standards Association. The terms HDMI and HDMI High-Definition Multimedia Interface, and the HDMI logo are trademarks or registered trademarks of HDMI Licensing Administrator, Inc. in the United States and other countries. Wi-Fi and Miracast are registered trademarks of Wi-Fi Alliance. USB Type-C is a registered trademark of USB Implementers Forum. All other trademarks are the property of their respective owners.