

**Series 2, fully-integrated dishwasher,
60 cm
SMV25AX00E**



Gentle - even to your ear. Our SilencePlus.

Technical Data

Energy Efficiency Class (Regulation (EU) 2017/1369): F
Energy Consumption for 100 cycles Eco Programme (EU 2017/1369): 102 kWh
Maximum number of place settings (EU 2017/1369): 12
The water consumption of the eco programme in liters per cycle (EU 2017/1369): 11.7 l
Programme duration (EU 2017/1369): 3:30 h
Airborne acoustical noise emissions (EU 2017/1369): 48 dB(A) re 1 pW
Airborne acoustical noise emission class (EU 2017/1369): C
Cleaning performance: A
Water consumption: 11.7 l
Total annual energy consumption 220 days: 224 kWh
Total annual water consumption 220 days: 2574 l
Built-in / Free-standing: Built-in
Removable top: No
Door panel options: Not possible
Height of removable worktop: 0 mm
Height of the product: 815 mm
Adjustable feet: Yes - all from front
Maximum adjustability feet: 60 mm
Net weight: 31.2 kg
Gross weight: 33.3 kg
Connection Rating: 2400 W
Fuse protection: 10 A
Voltage: 220-240 V
Frequency: 50; 60 Hz
Approval certificates: , VDE
Length electrical supply cord: 175 cm
Plug type: GARDY plug w/ earthing
Length inlet hose: 165 cm
Length outlet hose: 190 cm
Hidden heating element: Yes
Water protection system description: Triple water protection 24h
Child safety devices: No
Water softener: Yes
Top basket type: low
Adjustable upper basket: Single
Bottom basket type: low
3rd Rack: None
Optional accessories: SMZ5300, SMZ2014, SMZ2056, SMZ5000, SMZ5002, SMZ5003, SMZ5006, SGZ1010, SGZ8BI00, SMZ1051EU
Included accessories 2: vapor barrier plate
Number of place settings: 12
Color / Material panel: Black
Dimensions of the product (HxWxD): 815 x 598 x 550 mm
Dimensions of the packed product (HxWxD): 870 x 670 x 660 mm



**Series 2, fully-integrated dishwasher, 60 cm
SMV25AX00E****BOSCH - Header 6****BOSCH - Header 7****Gentle - even to your ear. Our SilencePlus.****BOSCH - Header 8**

-
- Fully integrated
 - 5 programmes: Intensive 70 °C, Auto 45-65 °C, Eco 50 °C, 1h65 °C, Pre Rinse
 - 1 special option: VarioSpeed
 - 4 cleaning temperatures
 - Heating pump
 - Dosage Assist
 - EcoSilence Drive
 - AquaSensor, Load-Sensor
 - Detergent Automation
 - Alternating spray
 - Regenerative electronics
 - Self-cleaning filter system with 3-fold corrugated filter
 - Interior tub material: Stainless Steel/Polinox
 - Push button top controls
 - LED programme status indicator
 - Acoustic end of cycle indicator
 - InfoLight
 - Colour of LED: red
 - Electronic delay timer: 3, 6 or 9 hours
 - LED salt refill indicator
 - LED rinse aid refill indicator
 - Vario basket system
 - silver/dark grey
 - Height adjustable top basket
 - 2 foldable plate racks in bottom basket
 - Cutlery basket in bottom basket
 - 2 cup shelves in top basket
 - AquaStop: Bosch warranty in case of water damage – for the lifetime of the appliance.*
 - Servo-lock
 - Glass protection technology
 - Front-adjustable rear foot
 - Incl. Steam protection plate
 - Product dimensions (HxWxD): 81.5x59.8x55cm

BOSCH - Header 1**BOSCH - Header 2****BOSCH - Header 3****BOSCH - Header 4****BOSCH - Header 5**

**Series 2, fully-integrated dishwasher, 60 cm
SMV25AX00E**

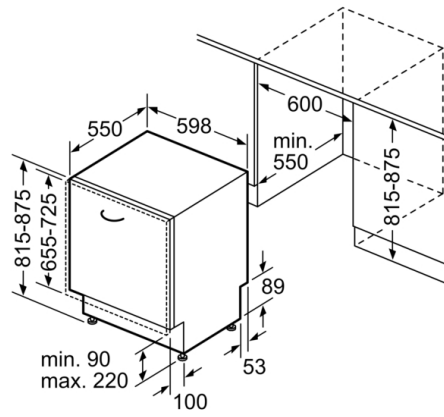
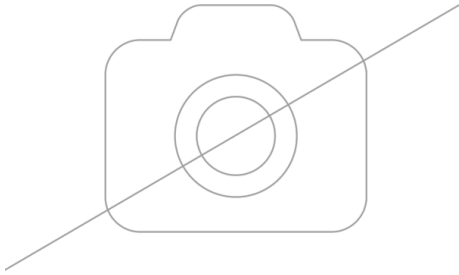

measurements in mm